

# INSTALLATION MANUAL

## STEP ADAPTOR SYSTEM

### MODEL NAME:

STEP 1

### MODEL NUMBER:

pf1020001xx

### FINISHES:

Chrome Polish/CP  
Brushed Nickel/BN  
Matte Black/MB

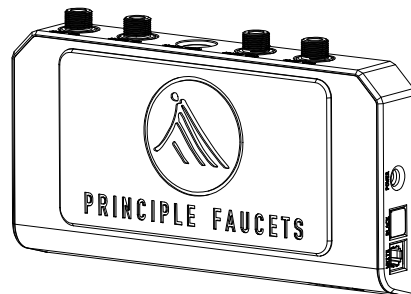
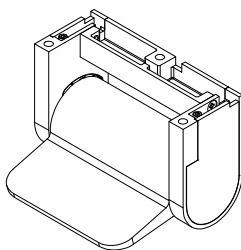

### NOTE:

- Step-by-step installation video available at [www.principlefaucets.com](http://www.principlefaucets.com)
- Read all instructions completely before beginning
- Read all installation requirements, warnings, care, and maintenance information before installation
- For product questions or installation support visit [www.principlefaucets.com](http://www.principlefaucets.com) or call (888) 293-2203

### Minimum Installation Requirements:

- 2" minimum toe kick depth
- 3.25" minimum toe kick height
- Unswitched 120V AC power outlet/access

### CERTIFICATION/STANDARDS:

- ASME A112.18.1/CSA B125.1
- NSF/ANSI 372
- NSF/ASME/CAN 61

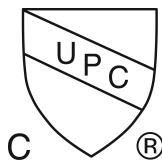

### Additional Tools You May Need:



Pliers

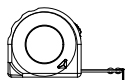

Measuring Tape

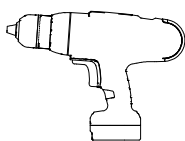

Power Drill

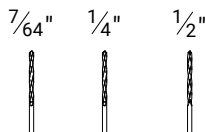

Drill Bits



Level



Pencil

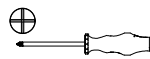

Screwdriver

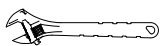

Adjustable Wrench



Painter's Tape



Bucket

# STEP Adaptor System

## Installation Example

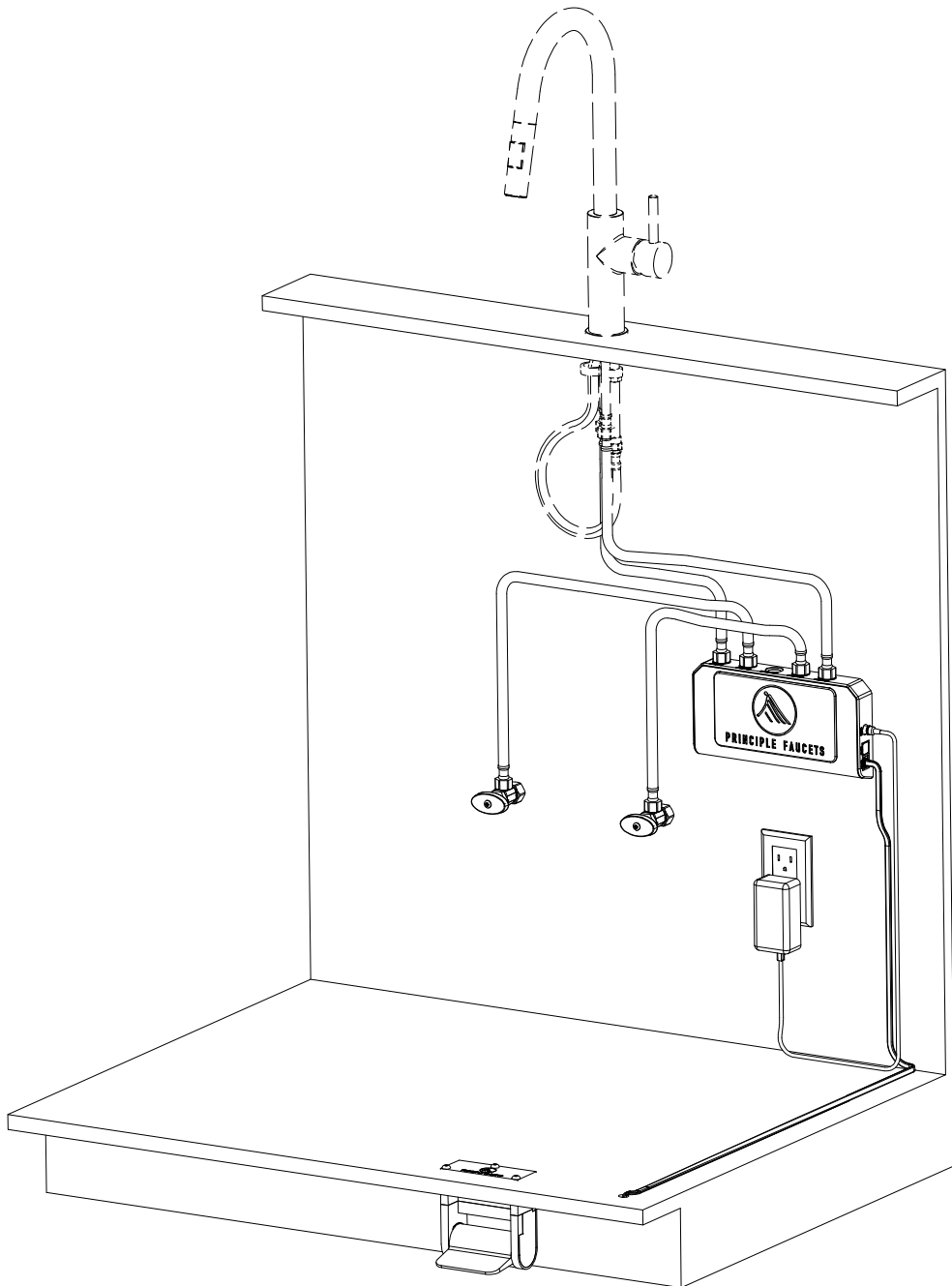

# TABLE OF CONTENTS

---

	Page
User Guide .....	4
Specifications .....	5
Parts Diagram .....	6
<b><u>Installation</u></b>	
Part 1 - Engine Box .....	7
Part 2 - Faucet .....	10
<b><u>Resources</u></b>	
Foot Pedal Spacer & Mounting Screw Guide .....	18
System Calibration .....	19
Troubleshooting .....	20
Warranty .....	23

# USER GUIDE

## **NOTE:**

- *Make sure the system is plugged in and powered on.*
- *Leave your faucet's hand-operated lever in the **open position** and at your desired starting temperature.*

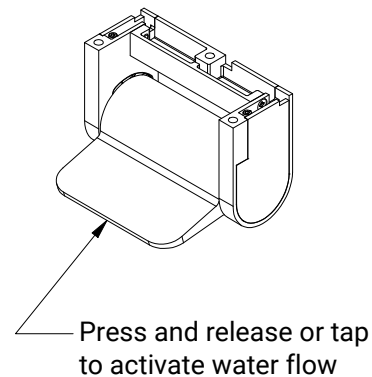
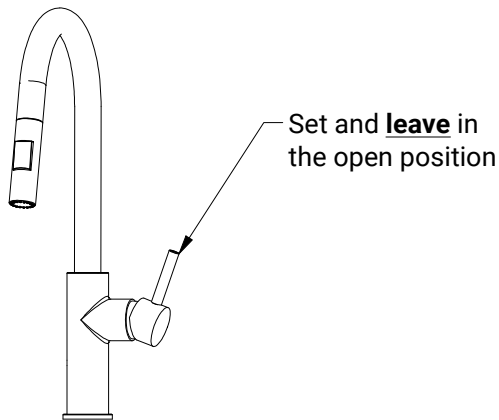

## **How to Operate the STEP System**

### Pedal Mode

- Start, stop, and adjust the flow of water like a gas pedal. The water shuts off automatically as soon as your foot is removed.

### TAP2FLOW Mode

- Tap once to activate TAP2FLOW; tap again to stop.
- In TAP2FLOW Mode the water will flow without your foot on the pedal.
- Stop the water at any time by tapping or pressing/releasing the pedal. TAP2FLOW will automatically shut off the water after 2 minutes.

### Faucet-Control Mode

- Tap the pedal twice to activate.
- This mode returns control of the water to the faucet. Use the faucet's hand-operated lever(s) as you would with a typical hand-operated faucet. To go back to Pedal Mode, simply start using the foot pedal again, leaving the faucet's hand lever in the open position.

### Temperature Control (for all modes)

- Change the water temperature at any time with the faucet's hand lever.

# PRODUCT SPECIFICATION

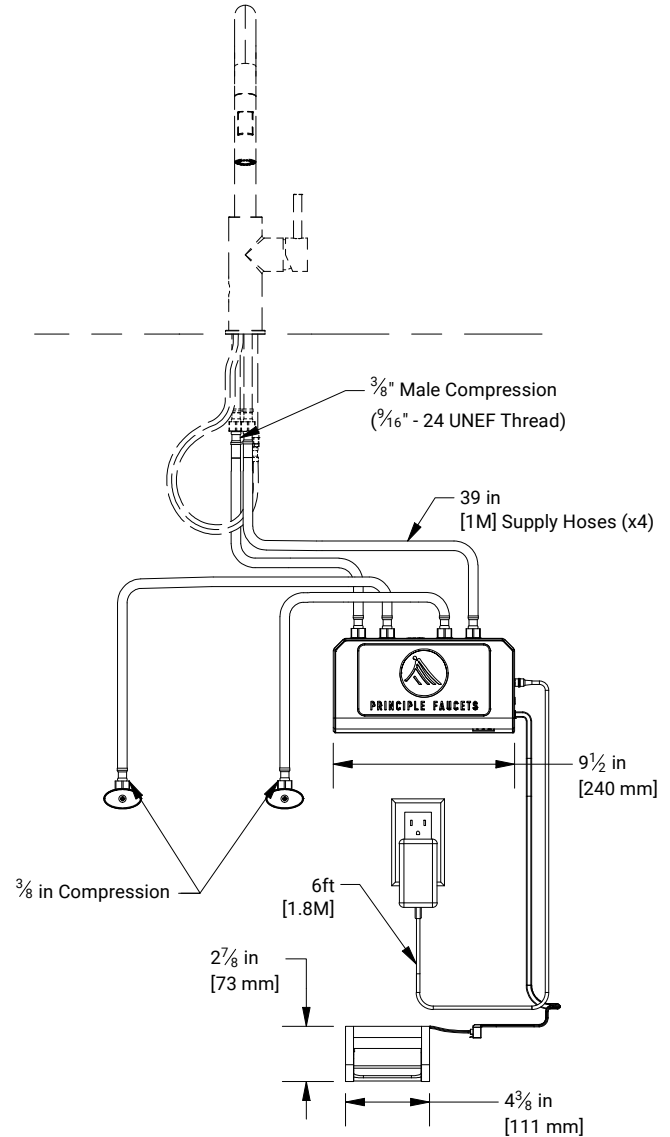
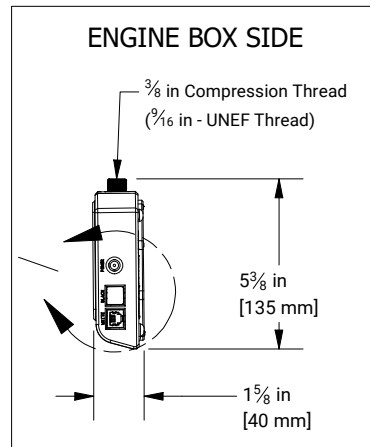
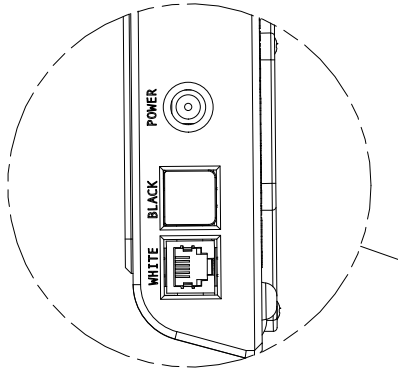

## Technical Information

### Installation Instructions:

Installation instructions are provided with the product; however, we recommend viewing the step-by-step installation videos found on our website at [www.principlefaucets.com/Installation](http://www.principlefaucets.com/Installation).

### Minimum Installation Requirements:

- 2" minimum toe kick depth
- 3.25" minimum toe kick height
- Unswitched 120V AC power outlet/access point

### Hoses:

Supply hoses: 39" (1M), 3/8" compression fittings (x4)

All supply hoses are provided for a typical installation. Adaptors may be needed if the water supply stop valve connections are not 3/8" compression fittings. They should be available at your local hardware store or by contacting a licensed plumbing professional.

### Compatibility:

The STEP system is designed to connect to almost any standard faucet. We supply hoses with 3/8" compression fittings. If you need a thread adaptor to connect the hoses we supplied with the connections on your faucet check with your local plumbing professional, hardware store, or give us a call at (888) 293-2203 ext.2. We are happy to assist. The STEP system is not recommended for electronic touch or sensor type faucets.

### Power Requirements:

You will need one unswitched, 120V AC power outlet located below the sink within 6' (1.8M) of the control box mounting location. For lavatory installations, a power outlet may need to be installed.

NOTE: Garbage disposals typically use a switched outlet. Switched outlets are not recommended for this product.

# PARTS DIAGRAM

STEP ADAPTOR SYSTEM

Model: STEP 1

Product Number: pf1020001xx

Ref#	Part Name
1	Faucet Supply Hose - Cold/Blue
2	Faucet Supply Hose - Hot/Red
3	EB Supply Hose (2pcs)
4	Comm Cable Link - White
5	Engine Box
6	Engine Box Wall Mount
7	Wall Mount Screws (3pcs)
8	EB Mounting Template Vertical
9	EB Mounting Template Horizontal
10	Cable Clips (2pcs)
11	Foot Pedal
12	Foot Pedal Mounting Plate
13	FP Mounting Screws - BLUE (3pcs)
14	FP Mounting Screws - YELLOW (3pcs)
15	FP Mounting Screws - RED (3pcs)
16	FP Mounting Screws - GREEN (3pcs)
17	Foot Pedal Spacer - 1/4in (4pcs)
18	Foot Pedal Spacer - 3/4in (2pcs)
19	Foot Pedal Mounting Template
20	Foot Pedal Cable - White
21	Power Supply
22	Hex Wrench
23	Drywall Anchor

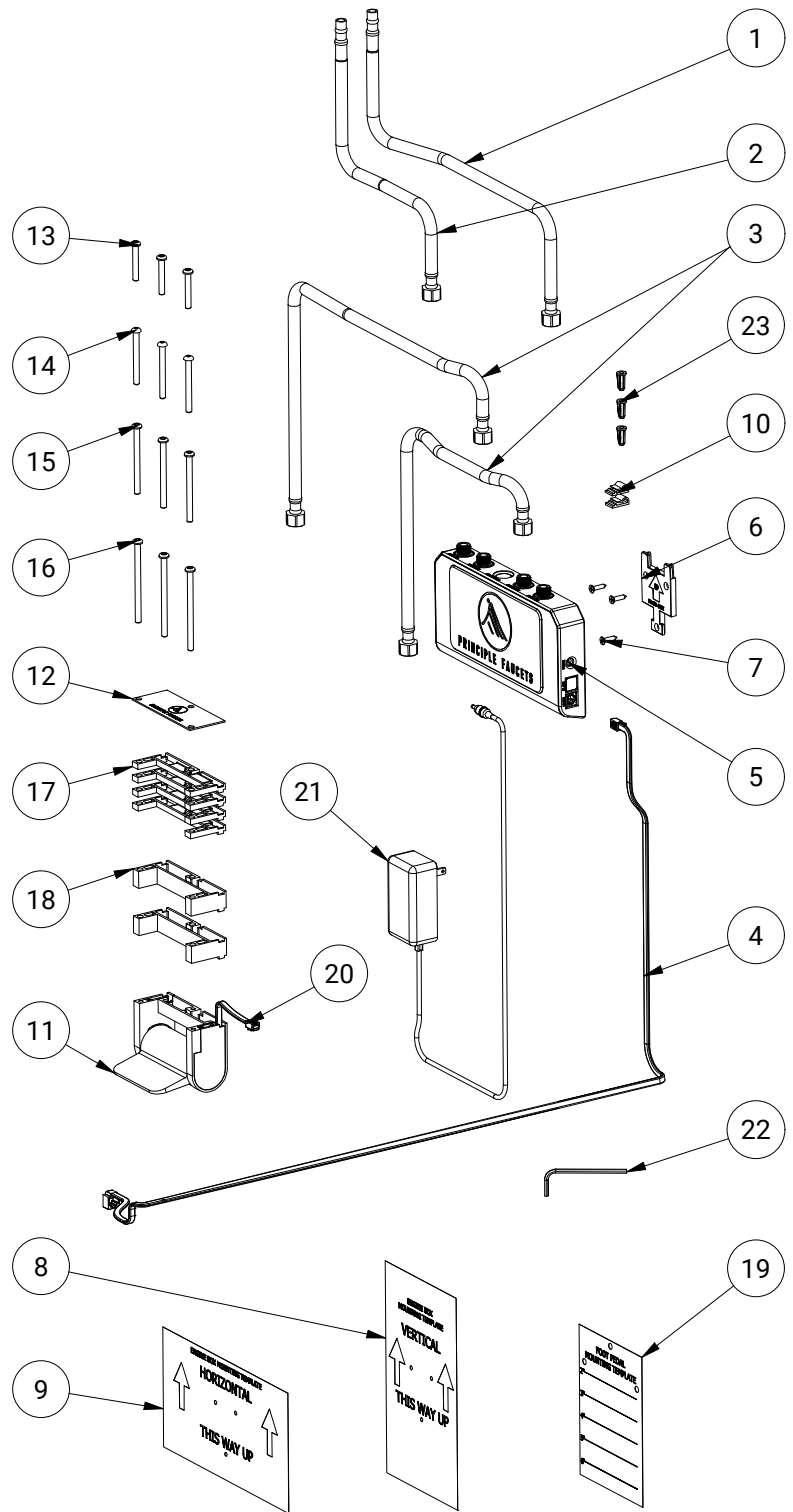

# INSTALLATION

## PART 1 - ENGINE BOX

1.

- A. Pick a location at the back of the cabinet where the Engine Box (5) is visible, but out of the way. We recommend the back face of the cabinet, but the side walls can be used as well. The location should be within 6ft of a standard unswitched 120V AC outlet.

NOTE: Use either the provided Horizontal (9) or Vertical (8) Engine Box Mounting Templates provided to position the Engine Box (5) as well as confirm the space needed for cable and hose clearance.

NOTE: The Engine Box (5) has a unique wall mounting system, which allows the box to be mounted facing up, left, right, or down, without readjusting the Wall Mount (6) in the sink cabinet.

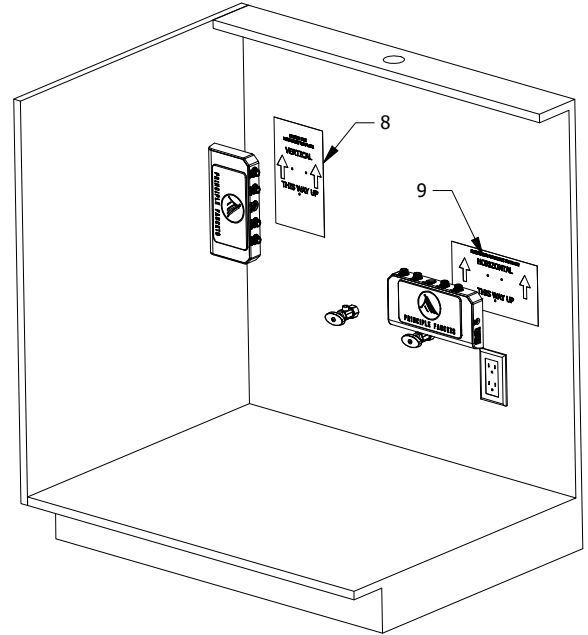

2.

- A. Level the Engine Box Mounting Template (8/9) and tape it in place. Be sure the mounting surface is flat and firm, to provide a strong anchoring position. Use a pencil to mark the center of each mounting hole. Then remove the template.
- B. With a  $\frac{7}{64}$ " bit, drill 3 pilot holes at the center of each mark. The holes should not exceed  $\frac{3}{4}$ " deep.

NOTE: If mounting the Engine Box (5) onto **drywall** or **plaster**, pilot drill with a  $\frac{3}{16}$ " bit and insert Drywall Anchors (23) into the holes.

WARNING: Drilling too deep may result in damage to pipes or electrical wiring behind the wall or in adjacent cabinets.

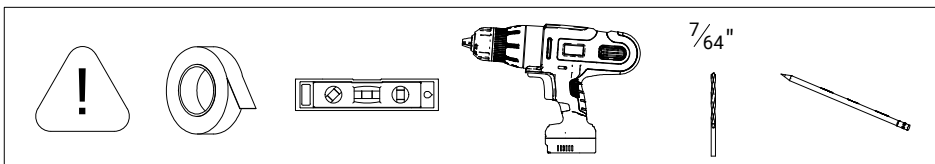
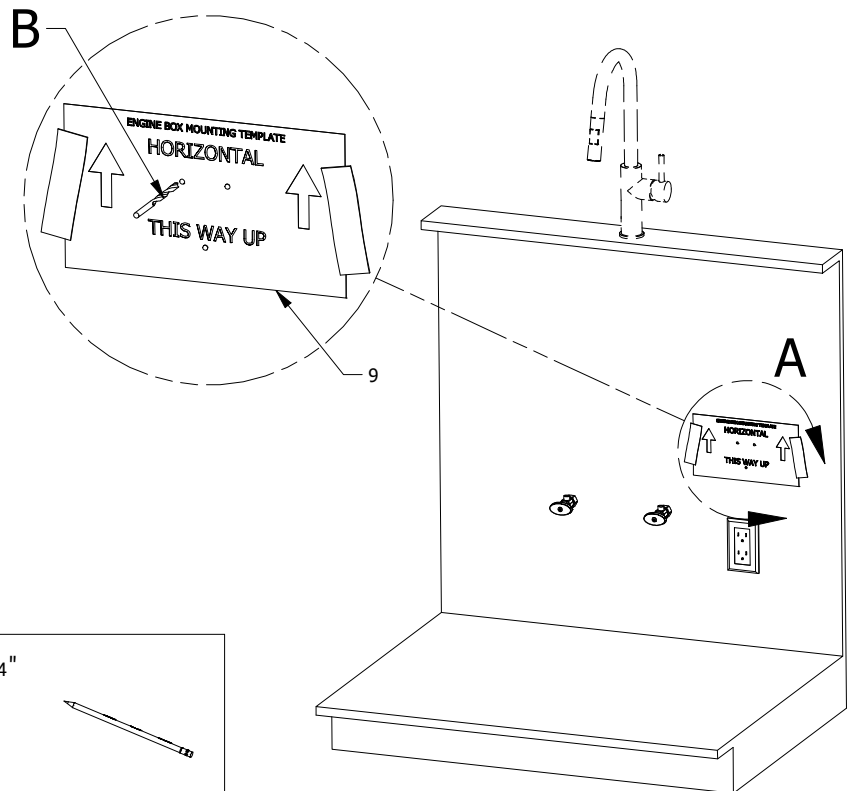

### 3.

- A. Align the Wall Mount (6) over the holes with the arrow side facing out. Secure the Wall Mount (6) with 3x Wall Mount Screws (7).

NOTE: If mounting onto a plaster or drywall surface, use the proper anchors.

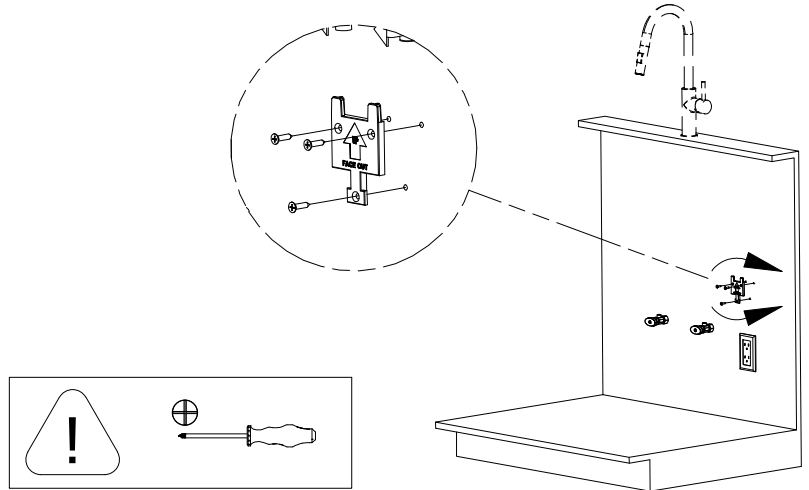

### 4.

- A. Test the Engine Box Wall Mount. Center the Engine Box (5) on the Wall Mount (6); press the Engine Box (5) against the wall until it fits over the Wall Mount (6); then, gently press down until snug. Check the minimum clearance for cable and hose connections (refer to the Engine Box Mounting Template [8/9] used).
- B. Remove Engine Box (5) by pushing up firmly until it clicks and then pull evenly away from the wall.

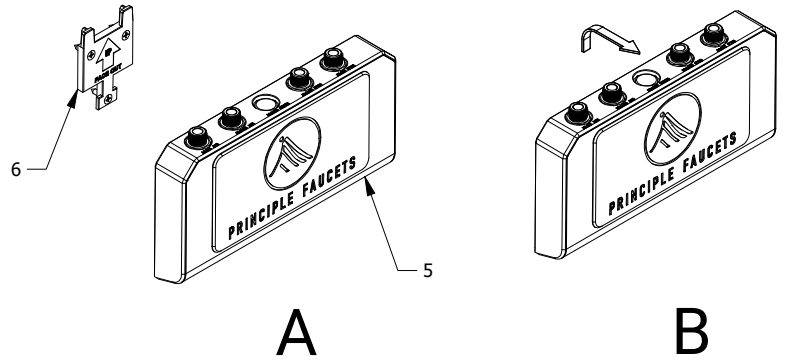

### 5.

- A. Connect the female ends of Faucet Supply Hoses - Cold/Blue (1) and Faucet Supply Hose - Hot/Red (2) to the corresponding Engine Box (5) ports designated by the red and blue dots. Tighten firmly with a wrench.
- B. Do not connect the male threaded ends of the Faucet Supply Hoses (1/2) to the faucet. This will happen at a later step.

NOTE: Do not crimp or twist hoses when tightening with the wrench.

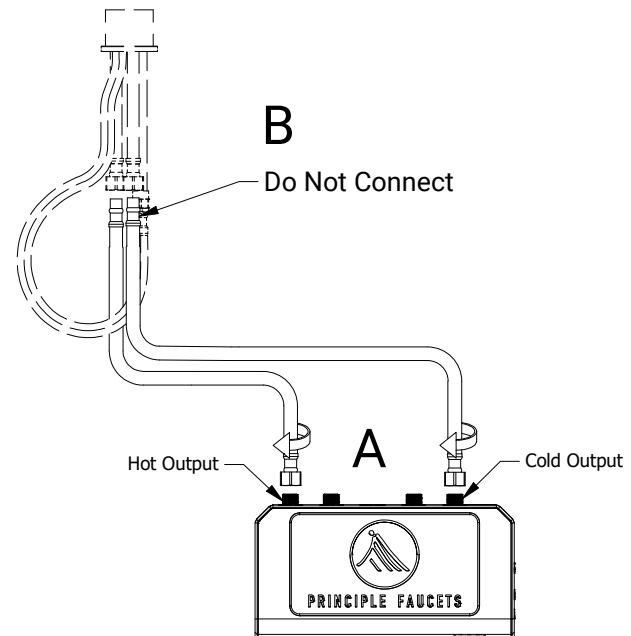
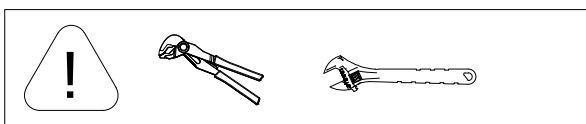



## 6.

- A. Connect the two EB Supply Hoses (3) to the hot and cold stop valves in the sink cabinet. The stop valves should have male  $\frac{3}{8}$ " compression ( $\frac{9}{16}$ "-24 UNEF threading). Tighten firmly with a wrench.
- B. Connect EB Supply Hoses (3) from the cold side Stop Valve to the cold input connection (middle right) on the Engine Box (5). Connect the other EB Supply Hose (3) from the hot side Stop Valve to the hot input connection (middle left) on the Engine Box (5). Tighten firmly with a wrench.

NOTE: Do not crimp or twist hoses when tightening with the wrench.

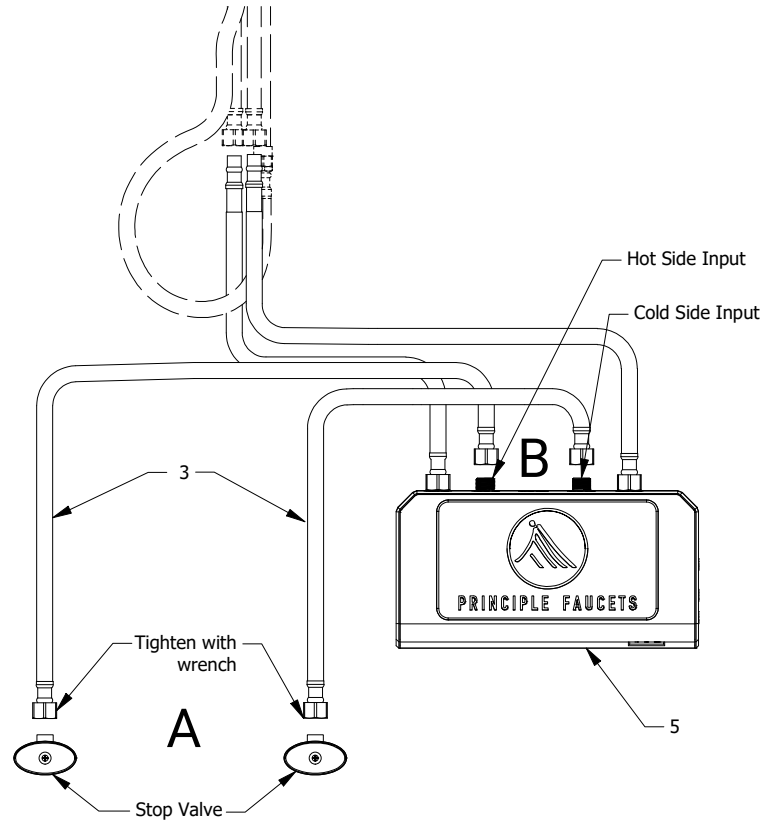
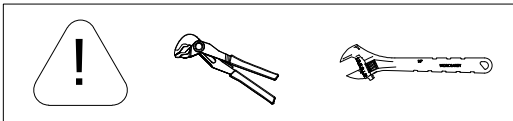

## 7.

- A. Secure the Engine Box (5) onto the Engine Box Wall Mount (6). Center the Engine Box (5) on the Engine Box Wall Mount (6) and press against the wall until you feel the Engine Box (5) slip over the Engine Box Wall Mount (6) and then press down firmly to lock it into place.

NOTE: Check the supply hoses to make sure they are not crimped or twisted.

NOTE: Create loops to take up any excess length of supply hose. Loops should have a minimum diameter of 8" to prevent kinks.

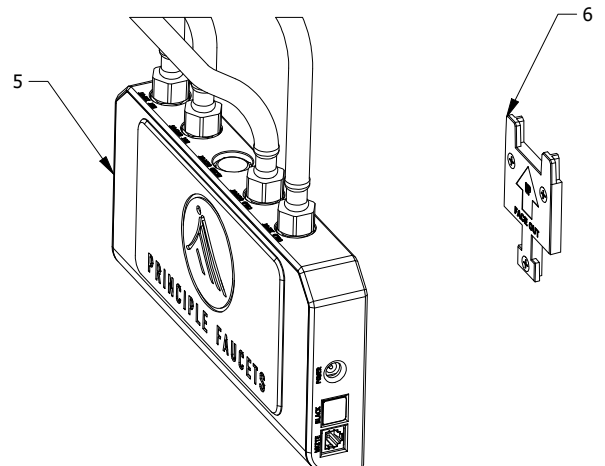

# INSTALLATION

## PART 2 - FOOT PEDAL

1.

- A. To find the best placement for your foot pedal, stand in front of your sink in the place where you typically work (wash hands, do dishes, etc.). The foot pedal should be positioned in the toe kick space where your foot rests most comfortably. The pedal can be positioned in front of either the right or left foot, based on your preference.

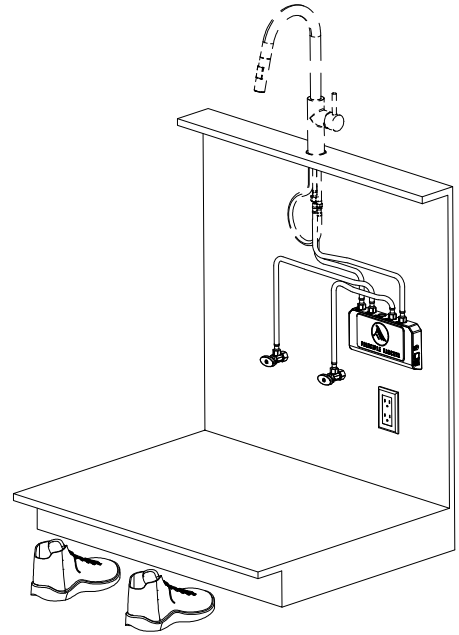

2.

- A. When you have chosen the perfect foot position, slide your foot back, away from the toe kick far enough to place the Foot Pedal (11) on the ground between your foot and the toe kick. Make a mark at the edge of the cabinet base, centered on the foot pedal. Continue the mark about 6" towards the back of the cabinet.

NOTE: Use a straight edge to make a clean and straight pencil mark.

NOTE: Place a strip of painter's tape down if you prefer not to mark your cabinets.

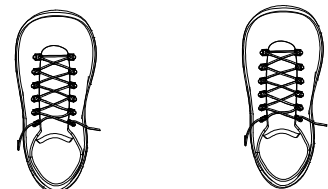
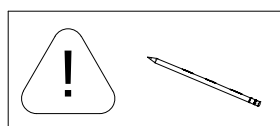
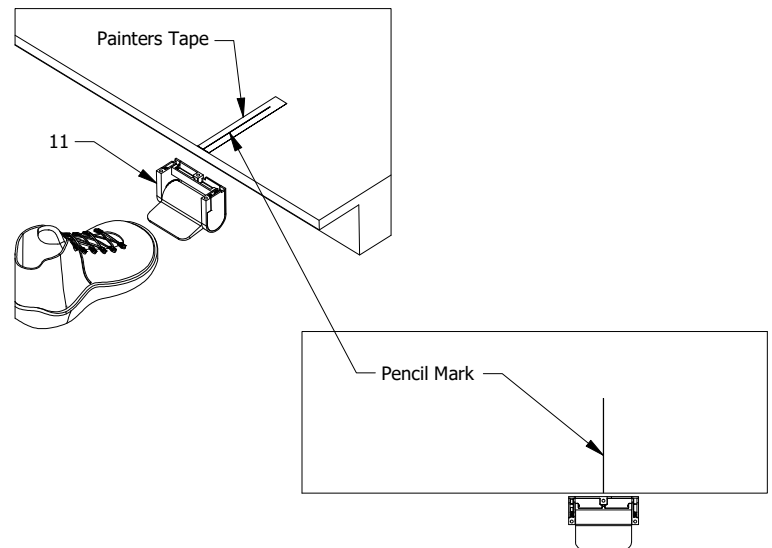

### 3.

- A. Measure the depth of the toe kick and record the measurement.

NOTE: The Foot Pedal requires a minimum 2" toe kick overhang.

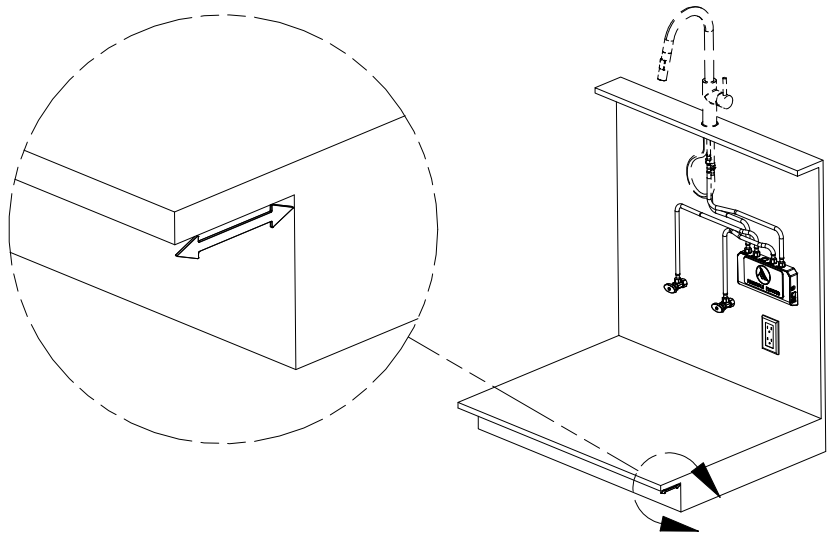
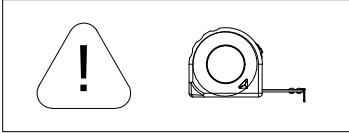

### 4.

- A. Fold the Foot Pedal Mounting Template (19) at the length measured for your toe kick depth.
- B. Use the edge of the cabinet or a ruler to make an even fold.

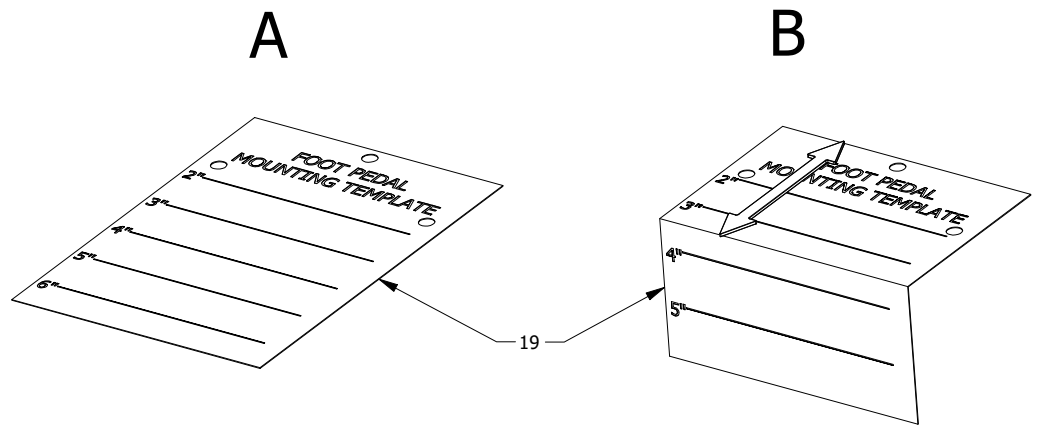

### 5.

- A. Place the Foot Pedal Mounting Template (19) on the cabinet base and align the hole at the top of the template with the line marked on the cabinet base. Make sure the fold is flush and square against the cabinet edge. Secure the template with tape.
- B. Mark the center of each hole with a pencil and then, remove the template. Drill a 1/4" hole at the center of each mark with a power drill.

NOTE: Pilot drilling with a 1/8" bit is recommended for accuracy.

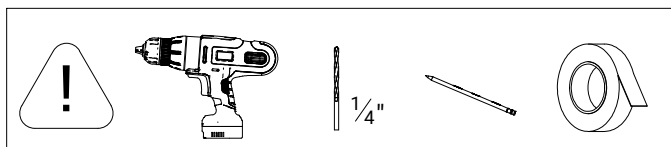
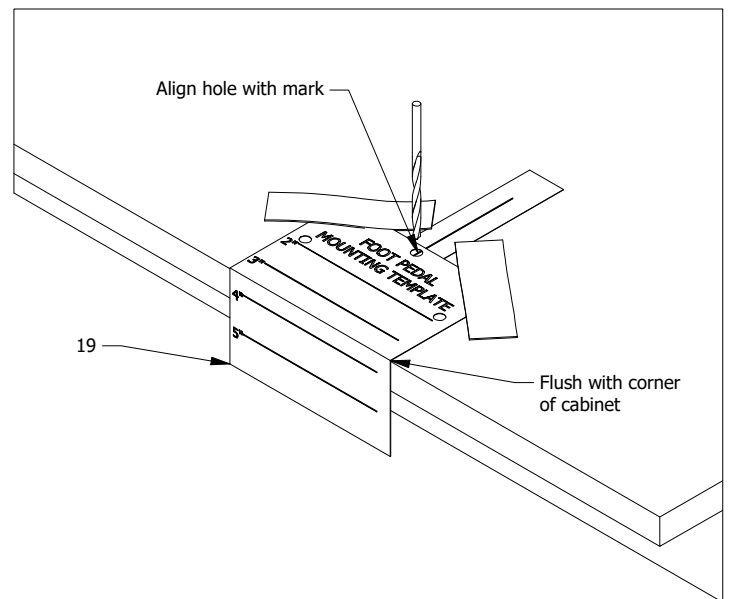

# 6.

- A. Measure the height of the toe kick and record the measurement.

NOTE: Be sure to measure the toe kick height at the back of the toe kick where the overhang and vertical face meet.

NOTE: Refer to the Foot Pedal Spacer and Screw Selection Guide (*Installation manual Pg.17 or at [www.principlefaucets.com](http://www.principlefaucets.com)*) for the recommended combination of spacers and mounting screws. The Spacers (17/18) provided will be combined with the foot pedal to position the pedal edge at the perfect height for comfort and convenience. If you have leftover spacers, recycle or save them in a safe place.

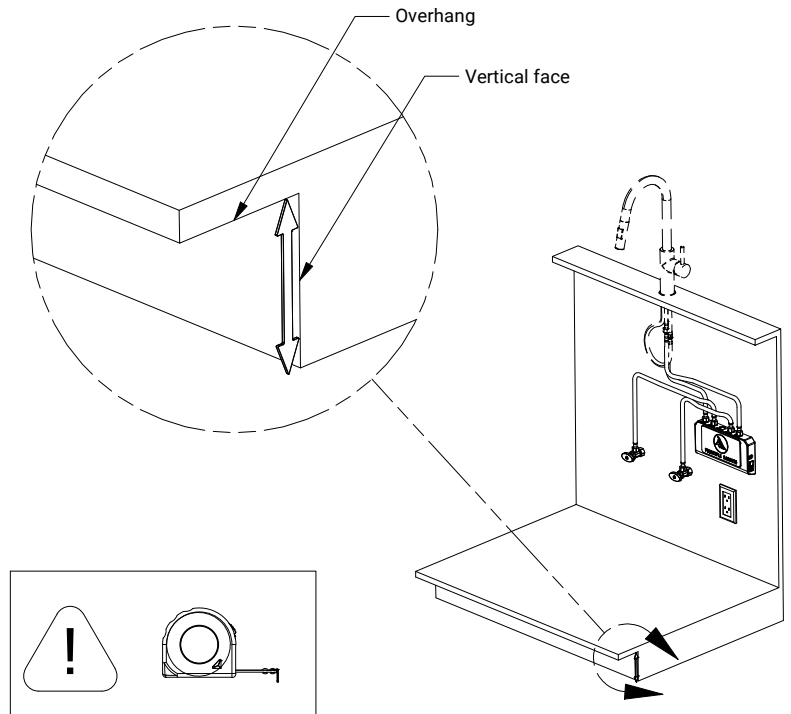

# 7.

- A. When stacking the spacers start with the larger  $\frac{3}{4}$ " spacers (18) and then add the  $\frac{1}{4}$ " spacers (17) on top.
- B. Thread the White Foot Pedal Cable (20) through the right side opening in the spacers as you stack them onto the Foot Pedal (11).

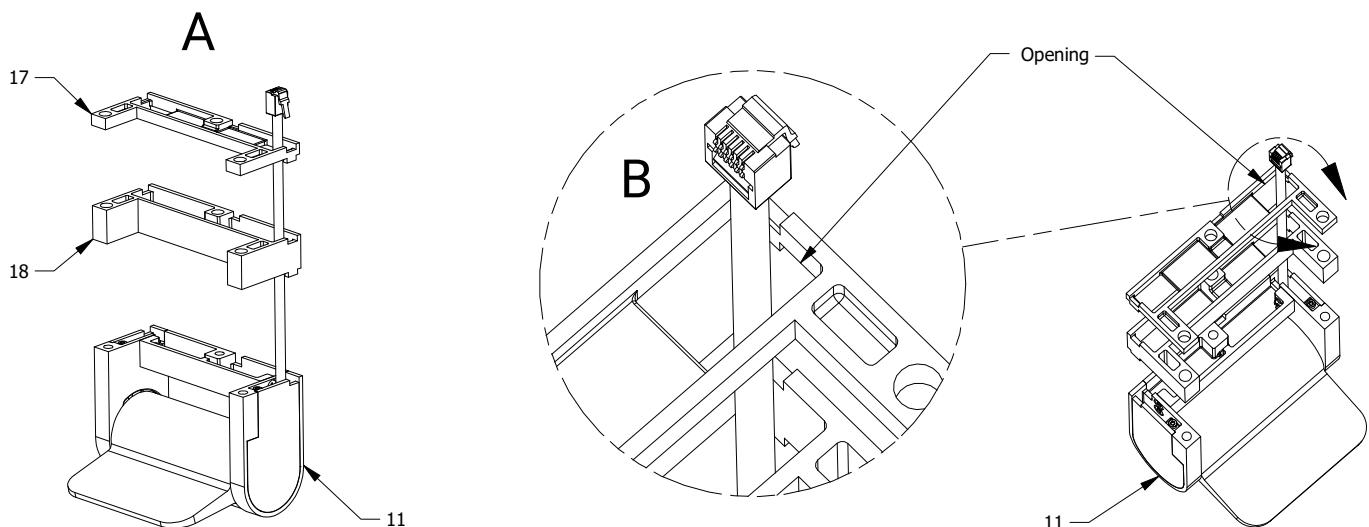

# 8.

- A. Position the White Foot Pedal Cable (20) to exit the stacked Spacers (17-18) on the right- or left-side, based on where you have placed the Engine Box (5) in the sink cabinet. The White Foot Pedal Cable (20) should be directed through the corresponding notch on the side of the Spacer(s) (17-18) stacked on the Foot Pedal (11).

Left side Engine Box install

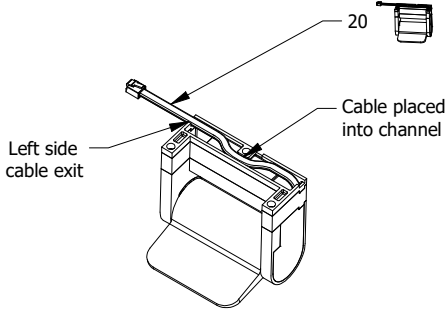
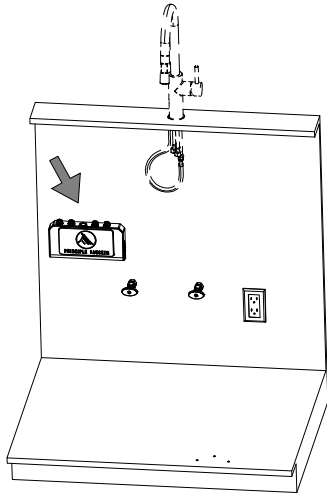

Right side Engine Box install

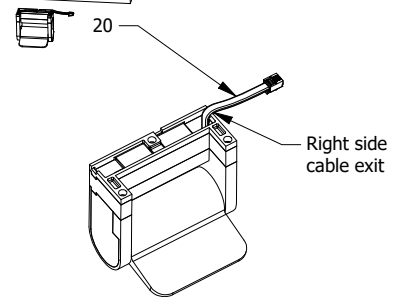
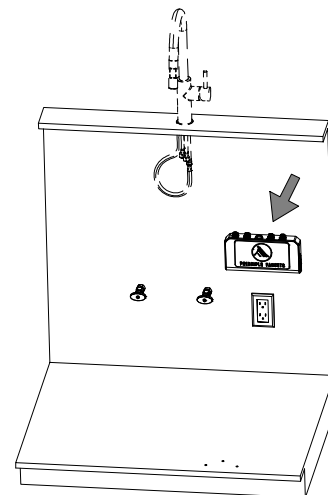

# 9.

- A. Position the Foot Pedal (11) with spacer stack, under the toe kick where the three holes were drilled. Place the Mounting Plate (28) over the holes in the cabinet base.
- B. Insert the three Foot Pedal Mounting Screws (13-16) through the Mounting Plate (28). Allow the Foot Pedal Mounting Screws to settle and align with the threaded holes in the top of the Foot Pedal (11).

NOTE: There are four different sizes of Foot Pedal Mounting Screws (13-16). The proper screw size will depend on the combination of the spacers used. Refer to the Foot Pedal Spacer & Mounting Screw Selection Guide for the proper screw size.

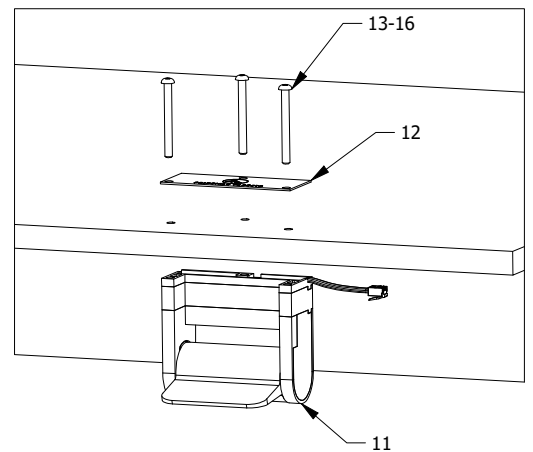

# 10.

- A. Take the Hex Wrench (22) and begin tightening each Foot Pedal Mounting Screw (13-16). Tighten approximately 2-3 rotations each and stop.
- B. Tighten the central screw slowly while checking that the White Foot Pedal Cable (20) is still in its notch. Finish tightening the remaining mounting bolts until the Foot Pedal is firmly in place. **Do not over-tighten!**

NOTE: Do not pinch the White Foot Pedal Cable (20) against the Foot Pedal (11) as you tighten the Foot Pedal Mounting Screws!

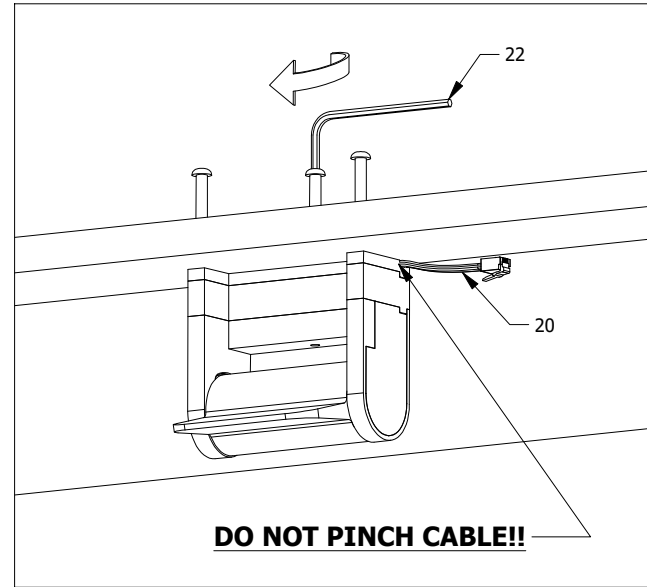
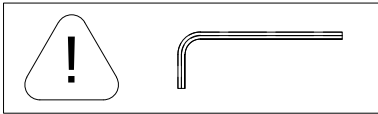

# 11.

NOTE: There are several ways to run the White Comm Cable Link (20) from the Foot Pedal (27) to the Engine Box (21). We recommend drilling a small hole in the corner of the cabinet (as shown here) to run the White Comm Cable Link (20) into the cabinet and back to the Engine Box (21). However, alternate routing of the White Comm Cable Link (20) could be:

- a. Through the toe kick, under the cabinet and up through a hole at the back of the cabinet base.
- b. Along the side of a dishwasher and back to the rear of the cabinet if adjacent to the sink cabinet.

If none of these options work for you give us a call on our Customer Support line at (888) 293-2203. We are here to help and may be able to come up with an alternative solution.

- A. Drill a 1/2" hole with a power drill, halfway between the face of the toe kick and the edge of the cabinet. The hole should be made in the front right corner or left corner (depending on the Engine Box (5) placement) of the sink cabinet base.

NOTE: Pilot drilling with a 1/4" bit is recommended.

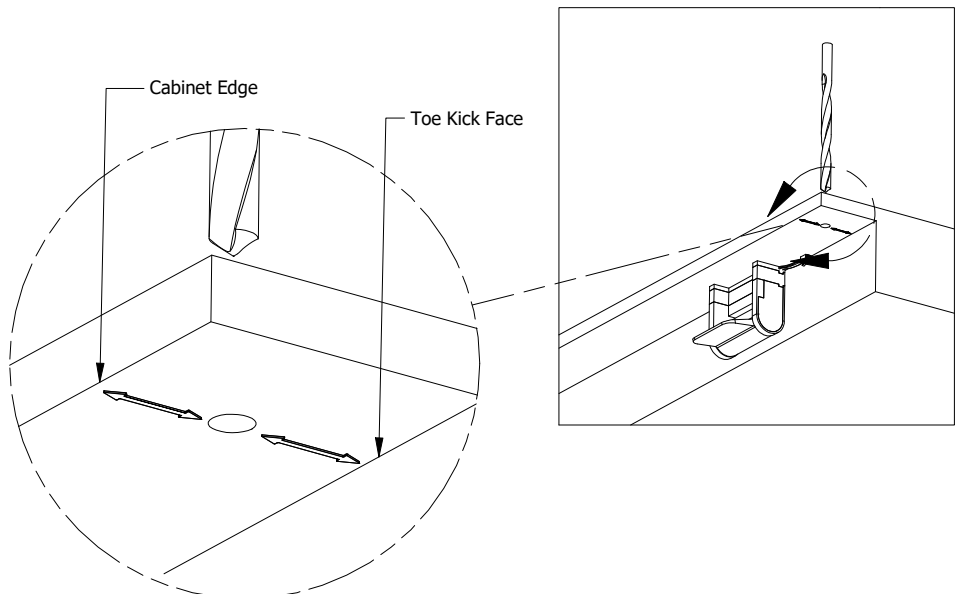
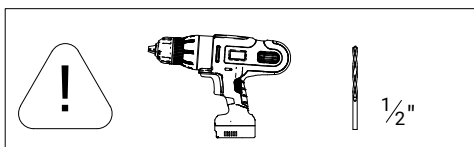

# 12.

- A. From the bottom side of the toe kick thread the male plug end of the White Comm Link Cable (4) through the hole.
- B. Leave 10 inches of the White Comm Cable Link (4) hanging below the toe kick.

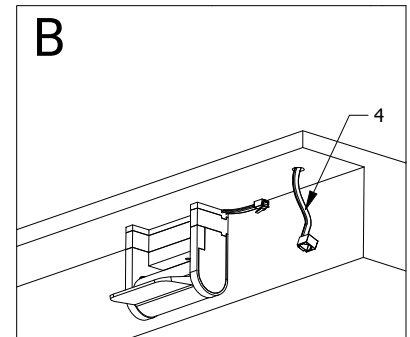
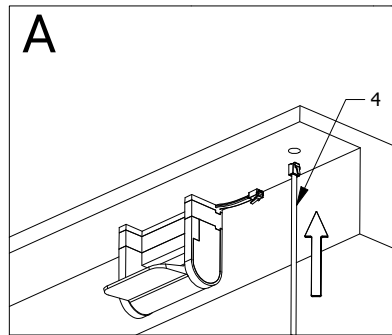

# 13.

- A. Connect the White Comm Cable Link (4) to the White Foot Pedal Cable (20) below the toe kick.
- B. Secure the White Comm Cable Link (4) under the toe kick with A Cable Clip (10). Remember to press the clip firmly against the cabinet base for 10 seconds to create a solid bond. Gently pull up any slack between the cable clip and the foot pedal.

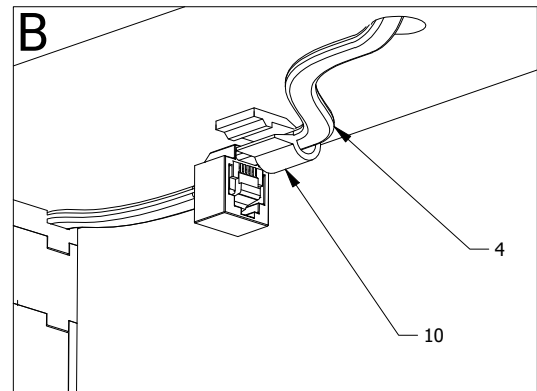
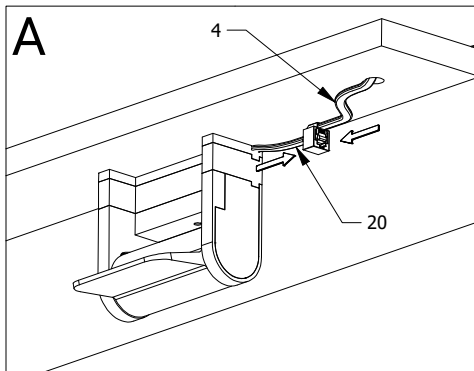

# 14.

- A. Connect the plug end of the White Comm Cable Link (4) to the Engine Box (5) port labeled "White". Collect any excess cable by making loops of 6"-8" minimum diameter and secure the loops loosely with the twist-tie provided.
- B. Use a Cable Clip (10) and twist-tie to collect any extra length of cable and secure it out of the way.

NOTE: Crimping of the White Comm Cable Link (10) could cause the system to not work properly. Do not pinch or fold the cable tightly.

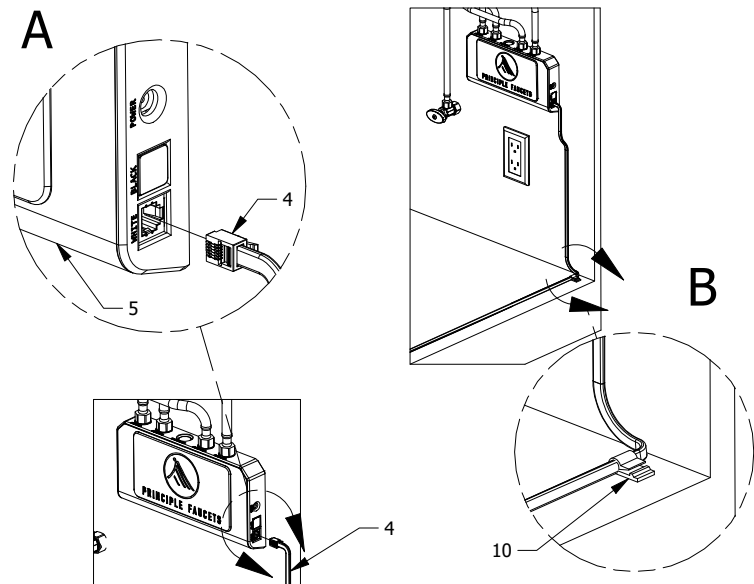

# 15.

- A. Take the Power Supply (21) and insert the plug end into the Engine Box port labeled Power.
- B. Connect the wall-plug end of the Power Supply (21) to the wall outlet.

NOTE: If all unswitched outlets are occupied in the cabinet we recommend adding a grounded outlet splitter or power strip. Either options can likely be found at your local hardware store.

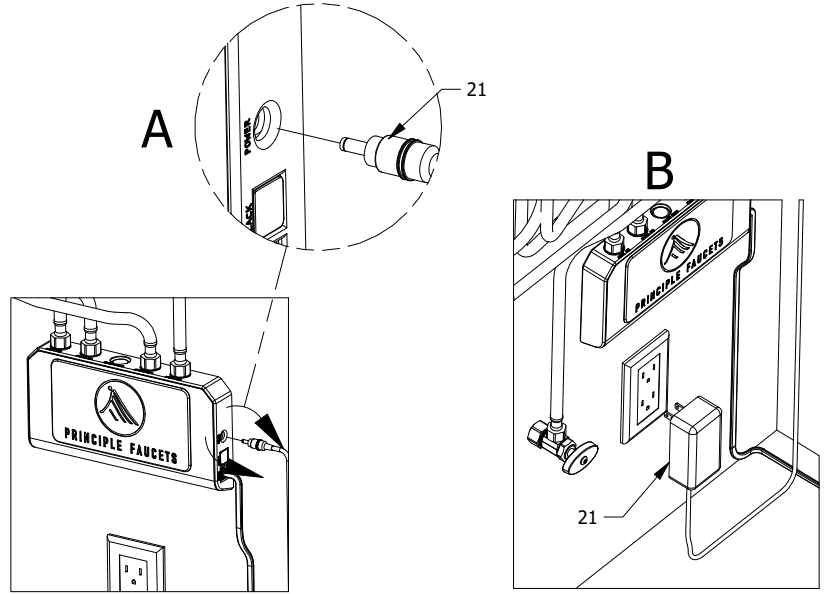

# 16.

- A. Confirm the system is powered on by checking that the led lights are on at the back of the Engine Box (5). Light L1 should be solid red. Light L2 will be blinking slowly green.
- B. Slowly depress the foot pedal until it stops and then release it. You should hear the valve motors activate.

NOTE: Consult the trouble shooting guide on page 20 if there are issues with steps A or B.

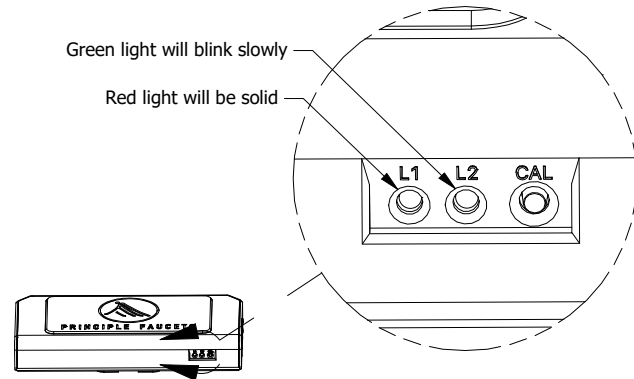

# 17.

With the system on and operational, flush the waterways to remove any debris from installation.

- A. Tap the foot pedal once to activate *Tap2Flow* mode. This will open the valves in the control box to allow water to pass through the system.
- B. Hold and aim both of the Faucet Supply Hoses (1 & 2) into a bucket. **Slowly open** one of the water supply stop valves to start the flow of water. Allow the water to run for 15 seconds and then shut off the water supply valve.
- C. Repeat steps A and B with the remaining water supply valve. Again, aim the Faucet Supply Hoses into the bucket.

NOTE: If a leak is detected, turn off the water at the stop valves. Then tighten the leaking connection.

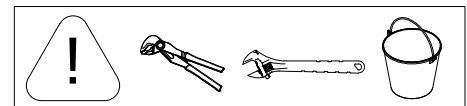
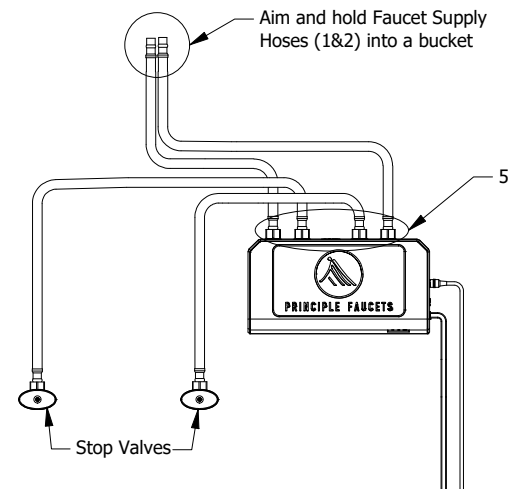



# 18.

- A. Connect the male threaded side of the Faucet Supply Hose - Cold/Blue (1) and Faucet Supply Hose - Hot/Red (2) to the corresponding cold and hot hoses attached to your faucet. Tighten firmly with a wrench.

NOTE: If your existing faucet does not have female  $\frac{3}{8}$ " compression threaded supply hoses, you will need to find an adaptor fitting at your local hardware store or by calling a licensed plumbing professional.

NOTE: Do not crimp or twist hoses when tightening with the wrench.

*We are here to help. If you have any questions call our Customer Support line at (888) 293-2203 for assistance.*

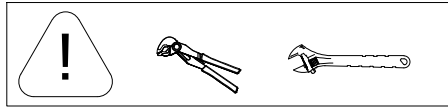
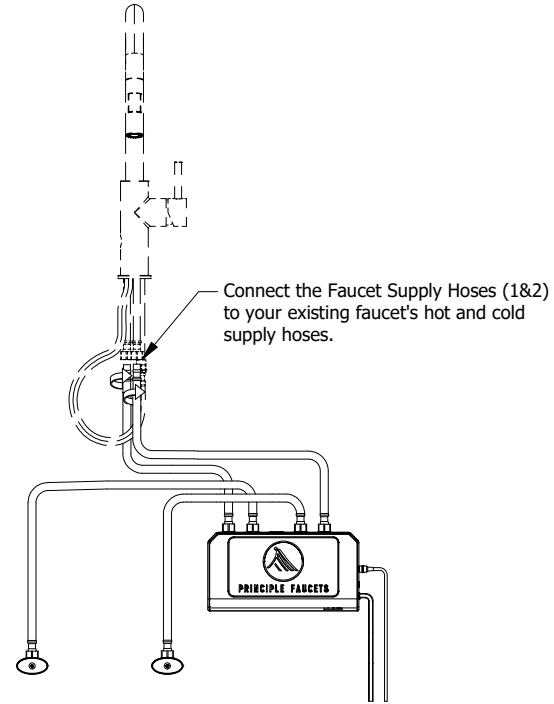

# 19.

- A. Open the cold and hot stop valves slowly. Check the hose connections at the Faucet Supply Hoses (1/2) for leaks.

NOTE: If a leak is detected, turn off the water at the stop valves and tighten the leaking connection. Open the cold and hot stop valves again, wait 2 minutes and check all connections again until no leaks are found.

**Congratulations! You are done with installation.**

**We would love to hear from you... please let us know your thoughts on the installation process and how much you love your new STEP foot pedal.**

**email us: [feedback@principlefaucets.com](mailto:feedback@principlefaucets.com)**

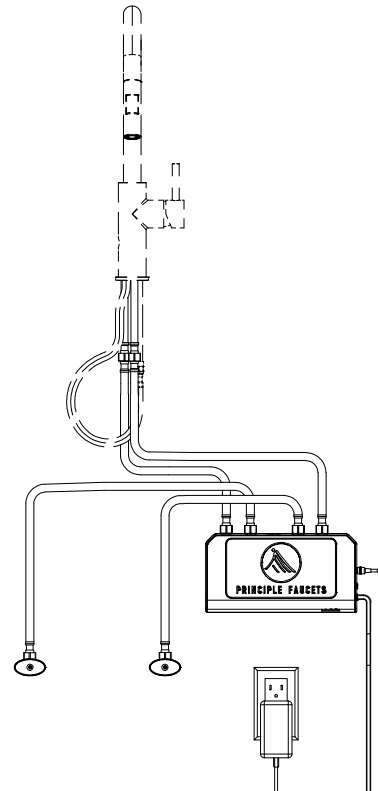

# FOOT PEDAL SPACER AND MOUNTING SCREW GUIDE

## $\frac{3}{4}$ " Cabinet Base Thickness

Toe Kick Height (in)	1/4" Spacer Qty	3/4" Spacer Qty	Total Spacers	Mounting Screw Color
**3.25 - 3.49	0	0	0	Blue
3.50 - 3.74	0	0	0	Blue
3.75 - 3.99	1	0	1	Blue
4.00 - 4.24	2	0	2	Blue
4.25 - 4.49	0	1	1	Yellow
4.50 - 4.74	1	1	2	Yellow
4.75 - 4.99	2	1	3	Yellow
5.00 - 5.24	0	2	2	Red
5.25 - 5.49	1	2	3	Red
5.50 - 5.74	2	2	4	Green
5.75 - 5.99	3	2	5	Green
6.00 - 6.25	4	2	6	Green

## $\frac{1}{2}$ " Cabinet Base Thickness

Toe Kick Height (in)	1/4" Spacer Qty	3/4" Spacer Qty	Total Spacers	Mounting Screw Color
**3.5 - 3.74	0	0	0	Blue
3.75 - 3.99	1	0	1	Blue
4.00 - 4.24	2	0	2	Blue
4.25 - 4.49	0	1	1	Blue
4.50 - 4.74	1	1	2	Yellow
4.75 - 4.99	2	1	3	Yellow
5.00 - 5.24	0	2	2	Yellow
5.25 - 5.49	1	2	3	Red
5.50 - 5.74	2	2	4	Red
5.75 - 5.99	3	2	5	Green
6.00 - 6.25	4	2	6	Green

\*\*Calibration Required - A system calibration may be necessary, if maximum water flow isn't achievable with the factory settings. Follow the steps for System Calibration in the Troubleshooting section of the Installation Manual.

# System Calibration

Your Principle System has already been calibrated during manufacturing; it is not required after installation. However, if re-calibration is necessary, review the following steps below.

System calibration has two primary goals:

1. *Reset the system to factory settings.* This may be necessary if you reinstall the entire system at a different sink or need to repair or replace a system component (eg. faucet, engine box, or foot pedal).
2. *Customize the maximum water flow position of the pedal.* We recommend that the leading edge of the pedal is positioned approximately 1" from the floor surface. However, the 1" target height may not be possible if the toe kick height is too short (eg. 3.25"-3.5"), or if the floor level has changed after installations (eg. a rug or padded mat added at the sink after installation). In these scenarios, the pedal may no longer be able to travel (pressed down) far enough to reach the factory set position for maximum water flow. Recalibrating the system will allow you to set a new maximum/full water flow position for the foot pedal, when it is pressed.

## System Calibration Process

**\*\*The calibration sequence will time out after 2 minutes of no input. If the system times out, simply start the calibration process over.\*\***

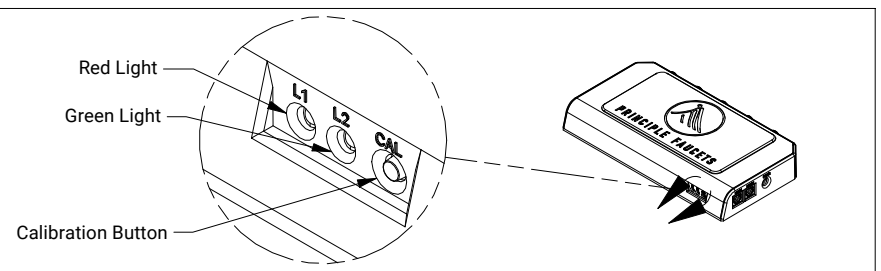
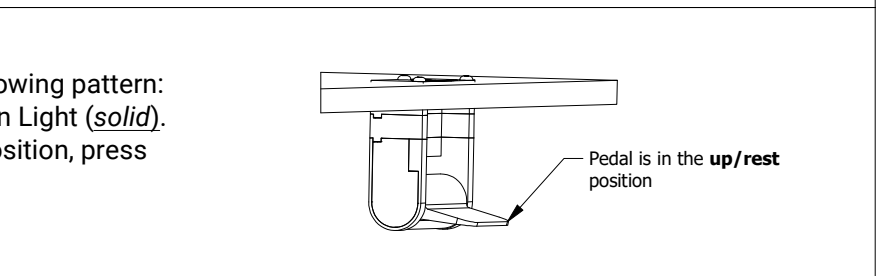
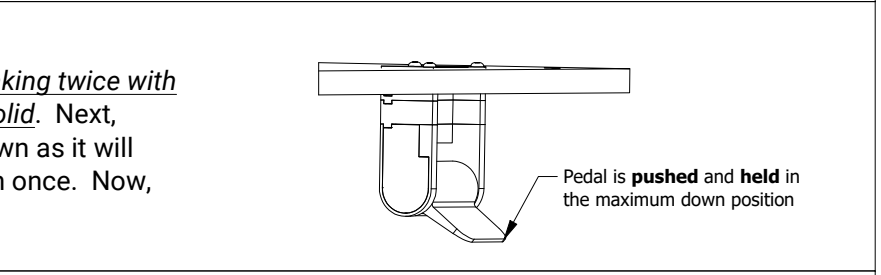
<ol style="list-style-type: none"><li>1. Locate the Calibration Button (CAL) at the back of the Engine Box (21).</li><li>2. Press and hold the CAL button (+2sec), until both red and green lights blink together, then release.</li></ol>	
<ol style="list-style-type: none"><li>3. Wait until the lights have changed to the following pattern: Red Light (<i>blink once with a pause</i>) and Green Light (<i>solid</i>). While the Foot Pedal (27) is in the up/rest position, press and release the CAL button once.</li></ol>	
<ol style="list-style-type: none"><li>4. Check that the Red Light has changed to <i>blinking twice with a pause</i> and the Green Light has remained <i>solid</i>. Next, press and hold the Foot Pedal (27) as far down as it will travel; then press and release the CAL button once. Now, release the Foot Pedal (27).</li></ol>	
<ol style="list-style-type: none"><li>5. The system will confirm a successful calibration when the lights change to the following pattern: Red Light <i>solid</i> and Green Light <i>blinking slowly</i>.</li></ol> <p>NOTE: If the calibration is unsuccessful, you may get an Error State Light Sequence. Explanations and solutions for the Error State Light Sequences can be found in the Trouble Shooting Guide under Error State Light Sequences.</p>	

# TROUBLESHOOTING GUIDE

## WATER LEAK

Problem	Possible Cause	Action
Water leaking from hoses	Hose not tightened	1. Shut off stop valves. Isolate the origin of the leak and tighten the hose(s) with either pliers or an adjustable crescent wrench. Do not over-tighten.
	Hose damaged	1. Shut off stop valves. Un-install the hose and inspect for holes, crimping, or a missing o-ring below the female threaded nut. Replace the hose, if needed, by calling Customer Support at (888) 293-2203 (ext.2).
Water leaking from inside Engine Box (5)	Internal seal failure	1. Shut off stop valves. 2. Contact Customer Support at (888) 293-2203 (ext.2) to arrange for a replacement.
Faucet leaking water	Unknown	1. Shut off stop valves. 2. Contact your faucet's manufacturer for guidance.

## ERROR STATE LIGHT SEQUENCE

There are two different Error State Light Sequences which will help to diagnose a system failure. The Error States are indicated by the red and green lights at the back of the Engine Box. If the system is in an Error State, the red light will blink rapidly with a pause, before repeating. The green light will produce either 1 or 3 blinks with a pause, before repeating to indicate the specific Error State.

We recommend visiting [www.principlefaucets.com/Support](http://www.principlefaucets.com/Support) for additional information and video tutorials.

Light Sequence	Possible Cause	Action
GREEN - 1 blink	Foot Pedal (11) not connected	1. Check that the White Comm Cable Link (4) is connected securely to the Engine Box (5) port WHITE. If connected, remove the cable plug from the Engine Box port and reinsert the plug, making sure it "clicks" into place. 2. Check that the White Comm Cable Link (4) is connected securely to the White Foot Pedal Cable (20). If connected, separate the cables and reconnect them, making sure it "clicks" into place.
	White Commcable Link (20) damaged	1. Check the White Foot Pedal Cable (20) and plug for damage. Check the White Comm Cable Link (4) plug, cable, and socket for damage. If damage is found, contact Customer Support at (888) 293-2203 (ext.2) to arrange for a replacement.
	White Foot Pedal Cable (36) damaged	
GREEN - 3 blink	Failed Foot Pedal (11) calibration	1. If the Foot Pedal (11) calibration did not register, perform the calibration process again. 2. Check and remove any obstacles that may prevent the Foot Pedal (11) from rotating a minimum of 15° from its starting point. Restart the calibration process. 3. Remove Foot Pedal Spacers (17-18) in increments of 1/4", until the minimum rotation of 15° can be achieved.

## GENERAL TROUBLESHOOTING

Problem	Possible Cause	Action
No water flowing when Foot Pedal (11) is depressed	Faucet hand lever(s) closed	1. Open the faucet's hand-operated lever(s) to allow for Foot Pedal (11) water flow control.
	Stop valves closed	2. Rotate stop valves in the counter-clockwise direction until fully open.
	Power supply to Engine Box (5) interrupted	1. Check that the wall-plug end of the Power Supply (21) is connected to an unswitched 120V AC power outlet. 2. Check that the Power Supply (21) plug has been inserted firmly into the Engine Box (5) jack labeled <b>"Power"</b> . 3. Contact Customer Support at (888) 293-2203 (ext.2) for further assistance.
	White Comm Cable Link (20) disconnected or inserted into the wrong Engine Box (21) jack	1. Check that the White Comm Cable Link (4) is inserted into the Engine Box (5) jack labeled <b>"White"</b> .
	White Comm Cable Link (20) damaged	1. Contact Customer Support at (888) 293-2203 (ext.2) for further assistance.
No water flowing when faucet's hand lever is operated	Stop valves closed	1. Rotate stop valves in the counter-clockwise direction until fully open.
	TAP2FLOW or FAUCET CONTROL are not activated	1. Tap Foot Pedal (11) once, for TAP2FLOW, or tap the Foot Pedal (11) 2-times, for FAUCET CONTROL mode.
Noise from the Engine Box (5)	Valve and motor activation	2. It is normal for the Engine Box (5) to emit some noise when the Foot Pedal (11) is used to activate the water flow. We recommend installing the Engine Box (5) as far back in the cabinet as possible, to limit noise.
Foot Pedal (11) water flow will not reach maximum water flow rate	Foot Pedal (11) cannot move far enough to reach full/maximum flow rate	1. Follow the System Calibration steps to create a custom, maximum water flow position for the Foot Pedal (11).
Water dripping from faucet spout	Faucet hand lever not closed	1. Adjust the faucet's hand-operated lever to the closed position.
	Foot Pedal (11) calibration error	1. Follow the System Calibration steps to reset the system.
	Foot Pedal (27) not returning to the rest/up position	1. Remove any obstacles or debris from around the Foot Pedal (11). Press and release the pedal.
	Valve system error	1. Contact Customer support for more information at (888) 293-2203 (ext.2). The control box may need to be replaced.
Engine Box (5) lights L1 & L2 are not lit	No power to Engine Box (5)	1. Reconnect the Power Supply (21) plug to Engine Box (5) jack labeled "Power". 2. Check that the power outlet has consistent power supply and is unswitched. 3. Change power outlets. 4. Contact Customer Support for more information at (888) 293-2203 (ext.2). The power supply may need to be replaced.

## GENERAL TROUBLESHOOTING (cont'd)

Problem	Possible Cause	Action
Foot Pedal (11) rattles or moves	Loose Mounting Screws (13-16)	1. Check that the Mounting Screws (13-16) are engaged with the Foot Pedal (11) threading. Tighten, if needed, with Hex Wrench (22).
	Incorrect Mounting Screws (13-16) length used	1. Measure the toe kick height and refer to the Foot Pedal Spacer and Mounting Screw Guide for the recommended mounting screw size.
	Uneven Foot Pedal (11) mounting surface	1. Ensure that the area under the toe kick, where the Foot Pedal (11) and toe kick make contact, is even and smooth.
Foot pedal water temperature does not change	Water supply stop valve closed	1. Open both water supply stop valves. 2. Recalibrate the system by following the System Calibration step.
	No hot or cold water supply available	1. Enter TAP2FLOW mode by tapping the Foot Pedal (11) once. Adjust the faucet's hand-operated lever to hot and then to cold. If water does not flow freely at either temperature setting, there may be an issue with the hot or cold water supply to the system. Open both water supply valves in the sink cabinet.
	Valve system error	1. Follow the System Calibration steps to reset the system to its factory settings. 2. Contact Customer support for more information at (888) 293-2203 (ext.2).

# **WARRANTY INFORMATION**

Principle Faucets' products have been manufactured under the highest standards of quality and workmanship. Principle Faucets warrants to the original consumer purchaser, for as long as the original consumer purchaser owns their home (the "Warranty Period" for homeowners), that this faucet will be leak and drip-free during normal use and all parts and finishes of this faucet will be free from defects in material and manufacturing workmanship. All other purchasers (including purchasers for industrial, commercial, business, and non-homeowners) are warranted for a period of 5 years from the original date of purchase.

Please review the full text regarding Principle Faucets' warranty terms, conditions, disclaimers, and limitation of liabilities at [www.principlefaucets.com/warranty](http://www.principlefaucets.com/warranty).

## **Specific Warranty Information for Electrical Portion of Principle Faucets' Products:**

Principle Faucets' warranty on all electrical components, including, but not limited to, the wiring and the power supply run for: (1) five years from the date of purchase for an Original Consumer Purchaser; or (2) one year from date of purchase for an Original Commercial Purchaser (but only so long as the Original Consumer/Commercial Purchaser continues to own the dwelling or premises).

Principle Faucets warrants the product's control box (which houses the electronic system) and finish will be free from defects in material and manufacturing workmanship for: (1) the lifetime of the Original Consumer Purchaser; or (2) five years from the date of purchase for the Original Commercial Purchaser.

## **What This Limited Warranty Does Not Cover:**

This Limited Warranty covers only those workmanship and material non-conformities specified above, and does not cover non-conformities or damages arising from any other cause, including without limitation, defects or damage due to the use of other than genuine Principle Faucets' parts, due to installation error, product abuse, product misuse or due to the use of cleaners containing abrasives, alcohol or other organic solvents.

## **Buyer's Right to Return Product:**

The Buyer may return an undamaged Product to Principle Faucets for a full refund within 6 months of purchase. To qualify, the Product should be in good condition, in working order, and include all original parts and packaging. We may require the original receipt or purchase order information to be included with the return to be valid. The Buyer may contact Principle Faucets through the warranty claim submission form on the website ([www.principlefaucets.com/warranty](http://www.principlefaucets.com/warranty)), or by the contact information provided below to initiate a return or warranty claim.

## **Warranty Claims:**

To initiate a claim, you may fill out a warranty claim at [www.principlefaucets.com/warranty](http://www.principlefaucets.com/warranty) or call customer support at 1-888-293-2203 extension 701. The buyer may also write Principle Faucets at PO Box 176 Rocklin, CA. 95677. For all warranty claims, proof of purchase is required.

*Principle Faucets reserves the right to update and change the Warranty and Product Return Policy at any time without notice. Please visit [www.principlefaucets.com/warranty](http://www.principlefaucets.com/warranty) for the most current policy information.*