

PRINCIPLE — FAUCETS

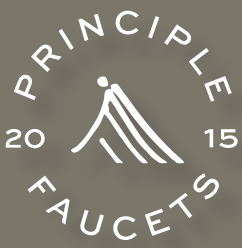

COMPANY & PRODUCTS



Evolving faucets and conserving water, one step at a time.

Welcome To The Future Of Faucets

Our pedal operated faucet systems provide a responsive and reliable hands-free way to start, stop and regulate water flow. You can also dial in the perfect foot pedal water temperature with the flick of a lever. Oh, and we keep the hand controls you know so well. You'll have the freedom to choose what is best for you while using the water you need, without the waste.

the **PRINCIPLE**



Our signature line of integrated kitchen faucets. Stay cleaner, work faster, and reduce water waste in a whole new way.

the **STEP**



A foot pedal adapter system designed to work with nearly any faucet in the kitchen or bathroom.



Hands Free

Our pedal system makes life easier at the sink. Free your hands to work smarter, quicker, and cleaner.



Improve Hygiene

Stop touching your faucet and start reducing the potential spread of germs in your household.



Water Savings (up to 44%)

Use the water you need without the waste.



Design & Function

Designed to look amazing in any home and engineered to install at almost any sink.

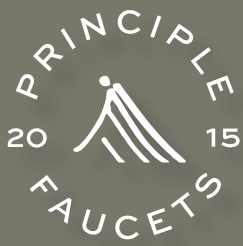

as featured in...

domino

THE WALL STREET JOURNAL.

BUSINESS OF HOME

Builder

KBB

**Up Next In
Commerce**

THE
STORY OF A BRAND

“Our whole family is obsessed with our new foot pedal - this simple addition allows us to only use water when we really need it, and I especially love that we don't have to touch the faucet after handling raw meat, eggs, and even messy art with the kids. A total win win for our family and the environment!”

- Shira Gill
home organizer, coach, author,
and founder of the #15minwin



Principle Faucets

Product Guide



Whether you need to replace a kitchen faucet or already have one installed, the Principle and STEP systems offer a hands-free, water saving solution for any home.

the **PRINCIPLE**



A fully integrated kitchen faucet and foot pedal system

IN THE BOX

Kitchen Faucet - Engine Box - Foot Pedal

KEY FEATURES

- A fully integrated kitchen faucet and foot pedal system
- Designed specifically for the kitchen
- Start, stop, and change the flow rate with the pedal
- Dedicated pedal temperature control located on the faucet
- Hand-control lever or foot pedal to activate water at any time

the **STEP**



A foot pedal adapter system designed to work with nearly any faucet in the kitchen or bathroom

IN THE BOX

Engine Box - Foot Pedal

KEY FEATURES

- Connects to your existing faucet
- Designed for the kitchen or bathroom
- Start, stop, and change the flow rate with the pedal
- Conveniently change temperature with the faucet's hand lever
- Hand-lever control and pedal control interchangeably

PRINCIPLE

Kitchen faucet and foot pedal system



The next step in faucet design —
a fully-integrated system.

Enjoy a truly hands-free experience at the faucet, while staying cleaner, working faster, and reducing water waste.

KEY FEATURES

- Flexibility to use the hand control lever or foot pedal to activate water at any time.
- Start, stop, and change the flow rate with the pedal.
- Dedicated pedal temperature control located on the faucet.



FAUCET

Pull-down, dual-function spray head

ENGINE

Engine box mounts easily in sink cabinet

PEDAL

Foot pedal mounts in cabinet toe kick



CHROME



BRUSHED NICKEL



MATTE BLACK



- Call For Availability -

POLISHED NICKEL



POLISHED BRASS (living)



SATIN BRASS



VINTAGE BRASS (living)

Principle System

Specification Sheet



Style: Konrad

Model #: 1040001xx

Availability: Now

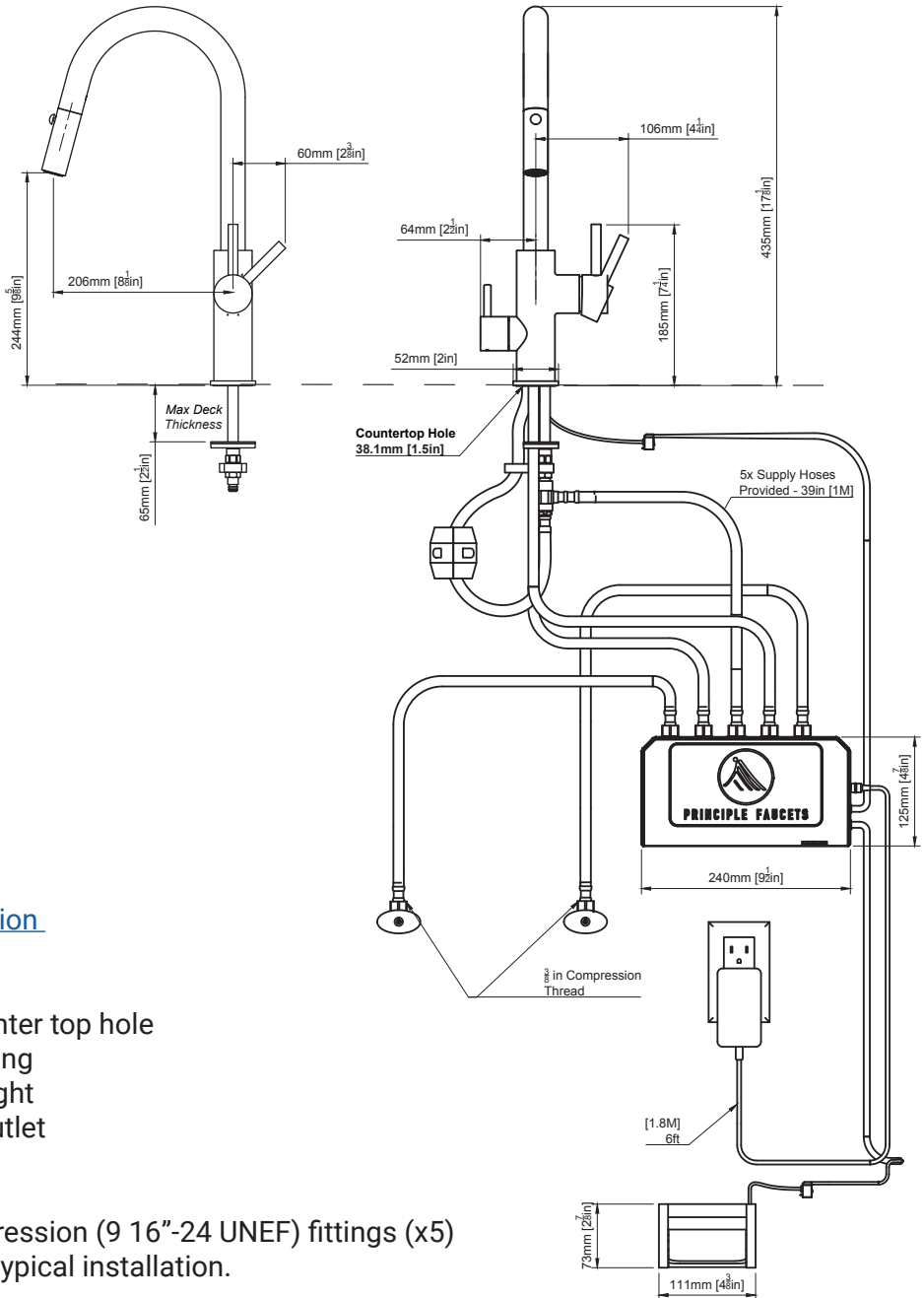
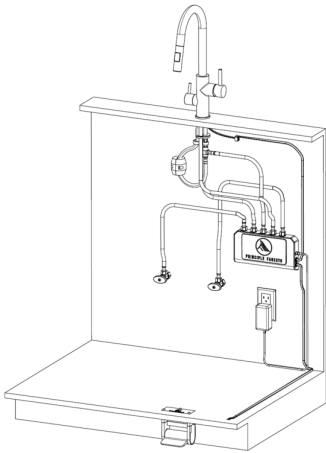

Technical Information

Faucet

Flow Rate - 1.8gpm (60psi/4.1bar)

Installation Instructions and Video

- www.principlefaucets.com/installation

Minimum Installation Requirements

- 1.375" min - 1.5" max diameter counter top hole
- 2" minimum cabinet toe kick overhang
- 3.25" minimum cabinet toe kick height
- Unswitched 110v-120v AC power outlet

Hoses & Connections

- Supply hoses: 39" (1M), 3/8" compression (9 16"-24 UNEF) fittings (x5)
- All supply hoses are provided for a typical installation.

Certifications/Standards

- cUPC
- ASMEA112.18.1/CSA B125.1
- NSF/ANSI 61
- NSF/ANSI372 - Lead Free
- CEC
- Compliant with all US Federal and State material regulations

Principle System

Design Lineup



Style: Vivienne

Model #: 1010001xx
Availability: Spring 2024

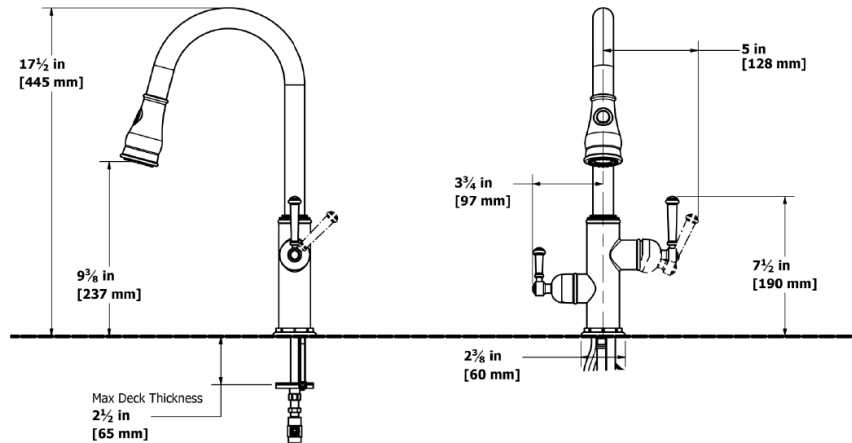

Style: Dexter

Model #: 1030001xx
Availability: Spring 2024

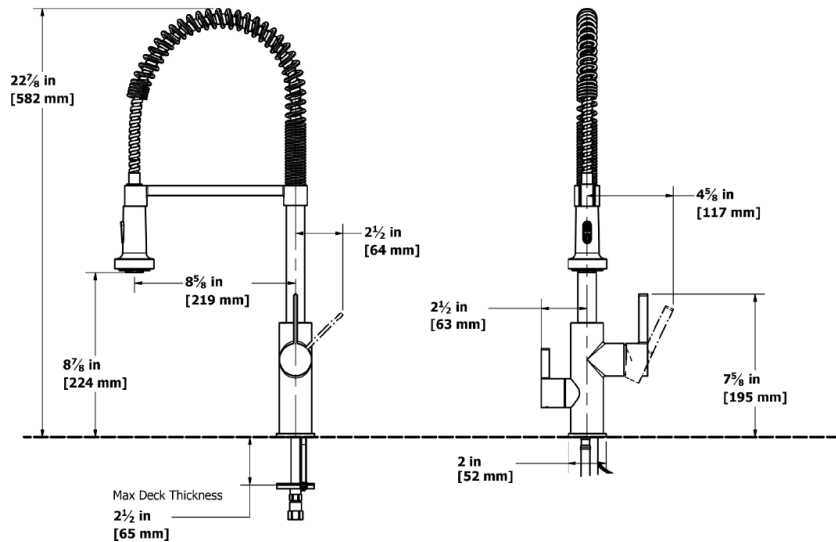

Style: Konrad

Model #: 1040001xx
Availability: Now

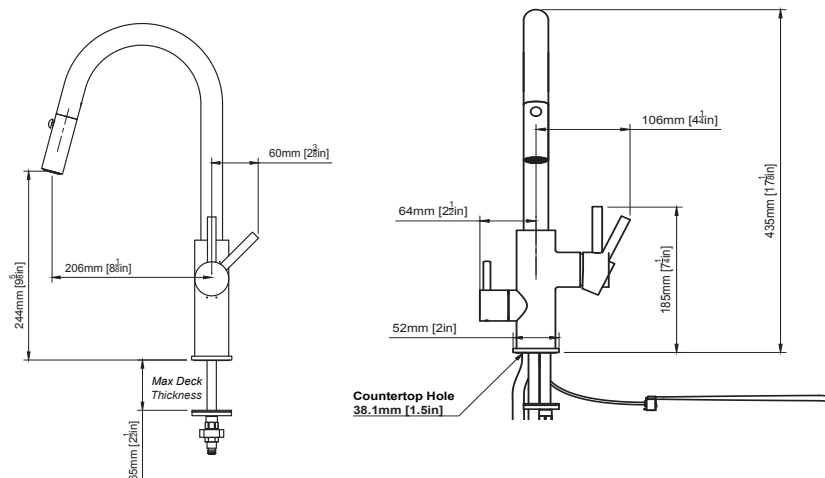

STEP

Foot pedal adapter system



The hands-free solution for your current faucet.

Your faucet...our foot pedal. This unique adapter system is engineered to work with nearly any existing or new faucet in the kitchen or bathroom. Gain the freedom of responsive hands-free water control while working cleaner, faster, and minimizing water waste.

KEY FEATURES

- Compatible with nearly all existing faucets in the kitchen or bathroom.
- Start, stop, and change the flow rate with the pedal.
- Temperature can be adjusted at the faucet.
- Designed to allow hand-lever control and pedal control interchangeably.

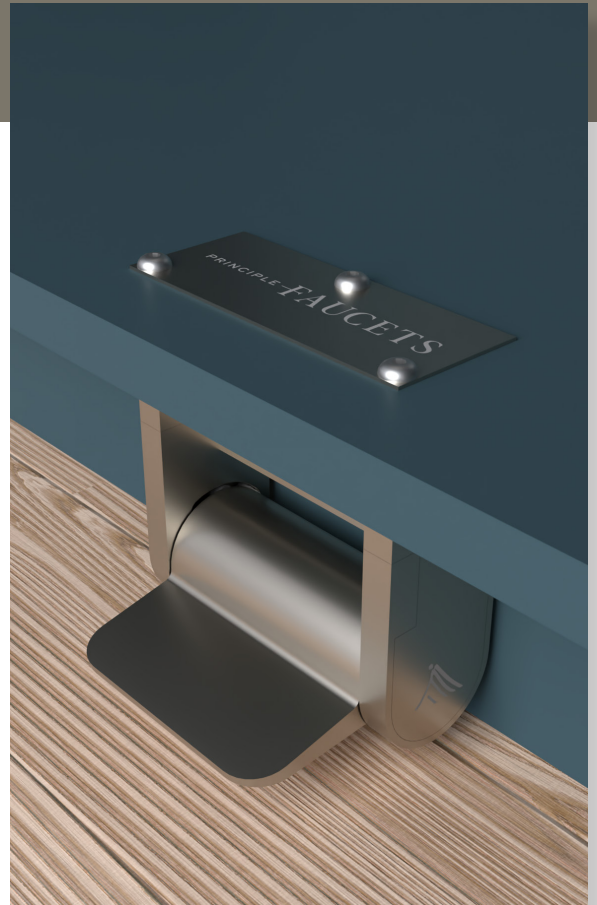

ENGINE

Engine box mounts easily in sink cabinet

PEDAL

Foot pedal mounts in cabinet toe kick



CHROME

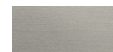

BRUSHED NICKEL



MATTE BLACK

- Call For Availability -



POLISHED NICKEL



POLISHED BRASS (living)



SATIN BRASS



VINTAGE BRASS (living)

STEP System

Specification Sheet



Style: STEP1

Model #: 1020001xx

Availability: Now

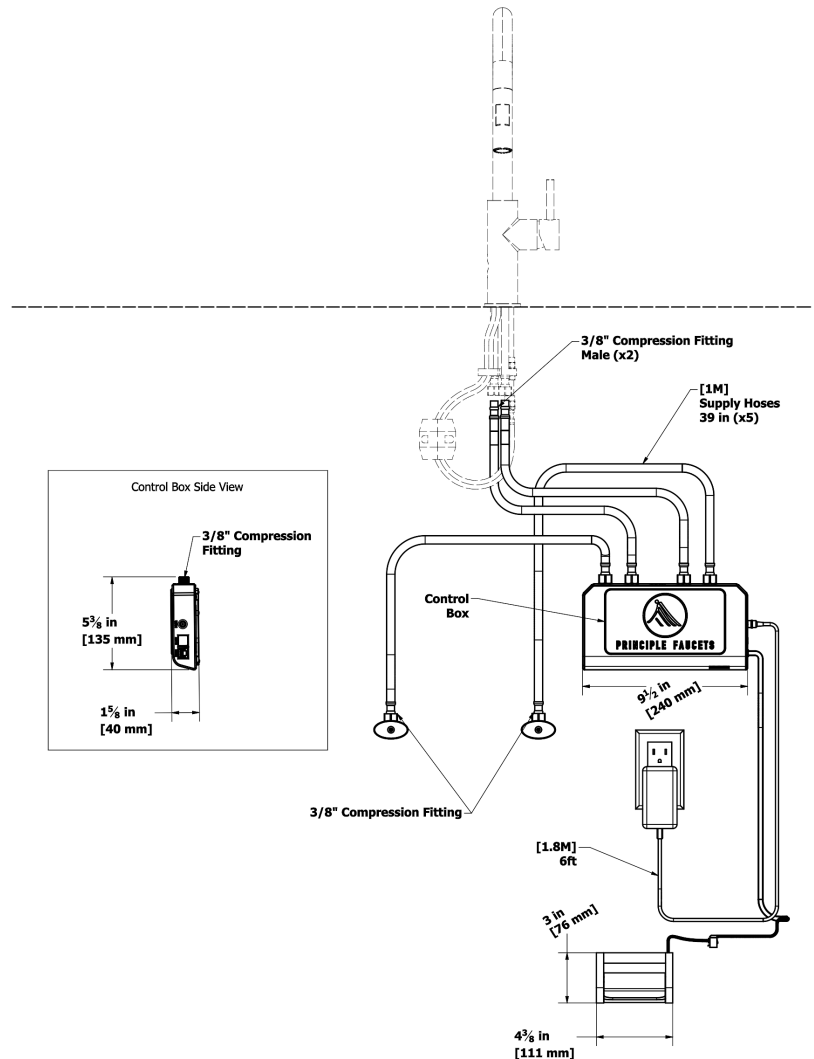
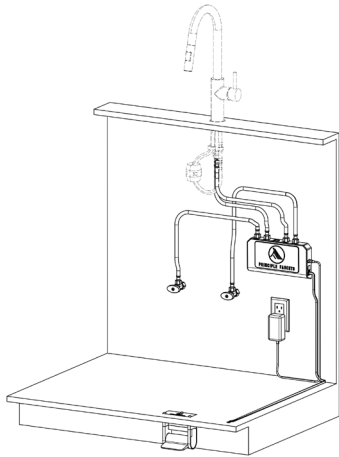

Technical Information

Installation Instructions and Video

- www.principlefaucets.com/installation

Minimum Installation Requirements

- 2" minimum cabinet toe kick overhang
- 3.25" minimum cabinet toe kick height
- Standard 110v-120v unswitched outlet

Hoses & Connections

- Supply hoses: 39" (1M), 3/8" compression (9 1/2"-24 UNEF) fittings (x5)
- All supply hoses are provided for a typical installation.

Compatibility

- We do not recommend combining the STEP1 with a touch or sensor style faucet.

Certifications/Standards

- cUPC
- ASMEA112.18.1/CSA B125.1
- NSF/ANSI 61
- NSF/ANSI372 - Lead Free
- CEC
- Compliant with all US Federal and State material regulations

Leaving the water running while using the faucet is one of the largest water-wasting behaviors at the sink...

yet it's one of the easiest to prevent.

Faucets need to change.

Over the past 20 years, improved efficiencies (mainly HE washing machines and low-flow toilets) have enabled US households to cut daily indoor water use by 22%.

Unfortunately during this time, no significant reduction in faucet water usage has occurred. Sensors and touch technology were introduced to the residential market with a focus on convenience, but an important gap remained for faucets designed with water conservation in mind.

AVERAGE DAILY INDOOR WATER USE PER HOUSEHOLD

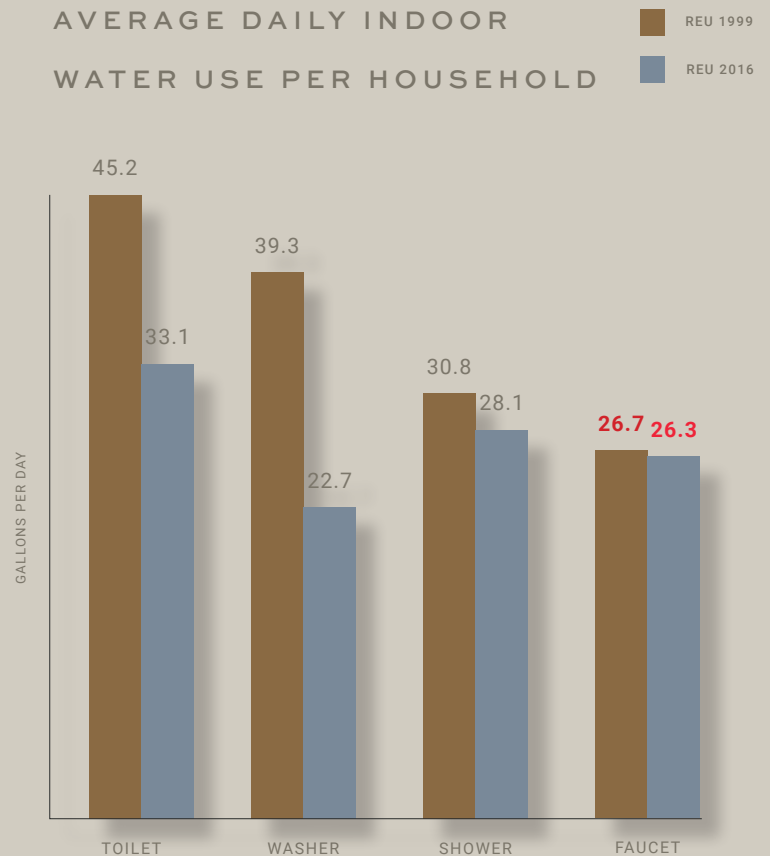

It's more than just wasted water!

There are a number of additional resources and inputs which end up being wasted along with the unused water flowing down your drain.

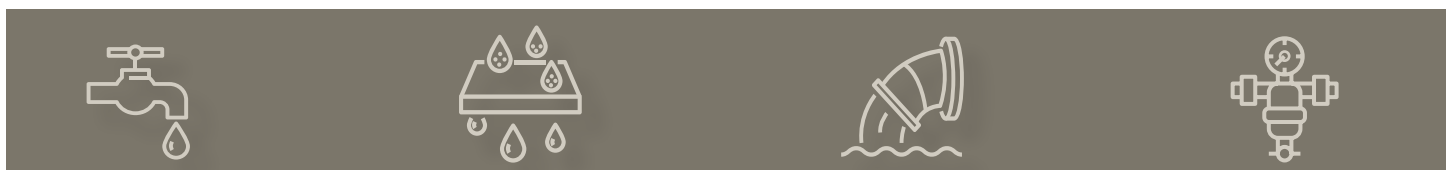

Electricity generated to pump and transport water.

Chemicals used to treat water for consumption.

Energy and resources used for waste-water treatment and disposal.

Unnecessary wear and tear on transportation and treatment infrastructure.

Principle Faucets Water Saving Trial

Overview

- 7 homes across coastal and central CA
- Water meters at the kitchen faucet were used to capture water consumption data
- Average water metering data ranged from 40-90 days
- Household size range from 1-6 people
- Age of adult participants range from 20-73 years old
- Age of child participants range from 2-12 years old
- Average reduction in water use of 25%
- Maximum water use reduction of 44%

Principle Faucets products can reduce water waste by

UP TO **44%**

Change In Water Consumption

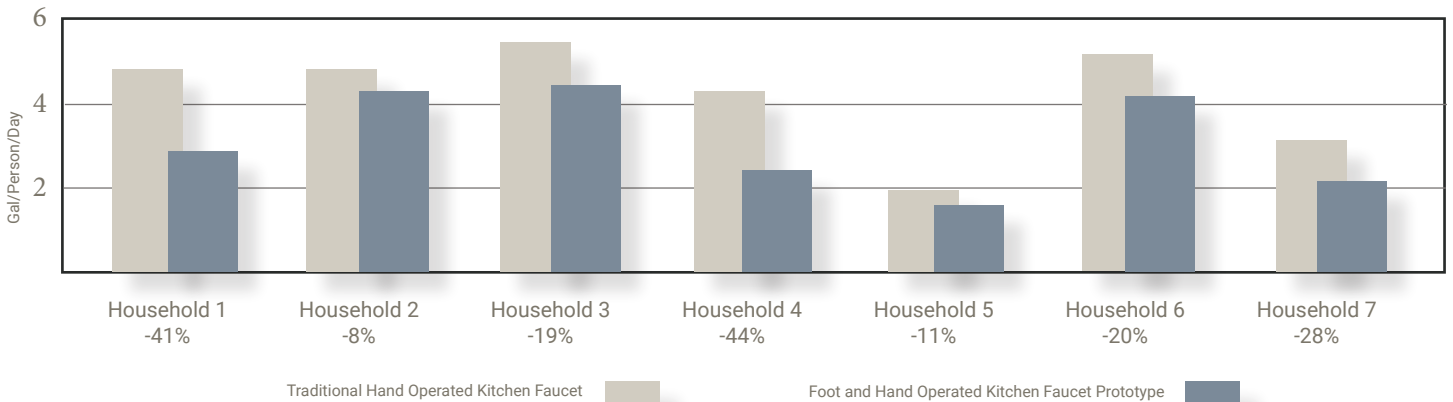

The 3 Year Plan

Over the next three years our goal is to install 100,000 foot operated faucet systems. This could save 180 million gallons of water per year. That is roughly a year's supply of fresh drinking water for 580k people. This reduction in water use could also curb carbon dioxide emissions by 8.6k metric tons per year.



=



=



180m
Gallons of
Water Saved Per
Year

580k
People with Fresh
Drinking Water For
a Year

-8.6k
Metric Ton
Decrease in CO₂
Emissions Per Year

Based on maximum water savings of 44% at the kitchen faucet, 3.2 g/p/d water consumption, and vehicle CO₂ emissions of 4.75MT/Yr.

PRINCIPLE—FAUCETS

The Principle Story

It all started with hands covered in raw chicken.

Lauren and Matt were carefree newlyweds and Lauren was cooking up a storm. Young, inexperienced, and freaked out by the potential spread of salmonella, they wondered why kitchen faucets didn't have those foot pedals you see in doctor offices; It would be so much more hygienic!

Fast forward a few years and they were no longer as concerned with germs as they were with the horrible California drought. Looking for ways to save water in their household, they realized flow restriction was all the plumbing industry really offered to cut water usage at the tap. The foot pedal became a hot topic between Matt and his great friend John. They hypothesized this concept actually had the potential to save by eliminating the water wasted when letting the tap continuously run between tasks. If you had more control over the water you used, you could use it better. They envisioned a more efficient, more functional faucet system.

They soon confirmed that foot pedals on the market were too limiting (lost hand control), a bit clunky (separate pedals for hot and cold water; tap dancing required), difficult to install (invasive to cabinetry), and aesthetically displeasing (Lauren no likey). So Matt and John bought a commercial-grade foot pedal, created their own unique plumbing system that overcame previous design limitations, and tested their concept with a multi-home water study program. Turns out all those seconds we lazy humans normally allow the water to run really do add up! Having a pedal enabled the user to start and stop the water effortlessly and with increased frequency. The pedal also allowed for easy adjustment of volume of water used at any given moment (like a gas pedal on a car). We were thrilled to see water usage at the sink cut by up to 44%.

Unwilling to ever wash dishes without a foot pedal again, we morphed into zealous revolutionaries hell-bent on reforming the faucet industry. We created a new faucet system. We designed a beautiful pedal.

It's time faucets evolved past standard hand control. Wave bye-bye to sensors and touch technology. Voice command? Please no! Foot pedals are the future. They are more functional, much more enjoyable to use, help you to work faster, keep the faucet and counter area cleaner, and most importantly, help to conserve Nature's most precious resource.

The Principle Team



LAUREN WALL

Creative/Marketing

From a very young age I imagined I would one day start a business. Raised by an entrepreneurial father and a mother who believed anything was possible, I felt creating something new was on my life path. I had a blast in college and earned a degree in business management. There I met my life partner. We traveled. I learned how to cook (the Barefoot Contessa taught me). I developed a passion for researching health and nutrition. I became slightly obsessed and spent an obscene amount of time in the kitchen. I had two kids and spent even more time in the kitchen. Working at the faucet in some capacity is where I like to be. Aligning my passions and principles with my life purpose is my ultimate goal. Today I feel I am living that dream.

JOHN PORTEOUS

Operations/Logistics

My upbringing surrounded by agriculture and farming in the Central Valley of California has installed a deep sense of responsibility regarding water and its conservation. I feel so honored and proud to be a part of the Principle Faucets team and develop these amazing products for people to enjoy. I view our work as an incredible opportunity to make a positive impact not only with our users lives in the home, but also in preserving one of our most precious resources. I hope you will join us in doing each of our parts in preserving a better tomorrow.

MATTHEW WALL

Sales/Product Design

Growing up in California, drought and water scarcity was a near constant issue which left a lasting impression. I leaned early on how important water was to our way of life and how often it has been taken for granted. I am grateful and excited to be working on a way to bring attention to water use in the home and help change water use behavior at the sink. I believe together we can make a difference and that we all have an obligation to help protect water for our selves and future generations.