

System Calibration

Your Principle System has already been calibrated during manufacturing; it is not required after installation. However, if re-calibration is necessary, review the following steps below.

System calibration has two primary goals:

1. *Reset the system to factory settings.* This may be necessary if you reinstall the entire system at a different sink or need to repair or replace a system component (eg. faucet, engine box, or foot pedal).
2. *Customize the maximum water flow position of the pedal.* We recommend that the leading edge of the pedal is positioned approximately 1" from the floor surface. However, the 1" target height may not be possible if the toe kick height is too short (eg. 3.25"-3.5"), or if the floor level has changed after installations (eg. a rug or padded mat added at the sink after installation). In these scenarios, the pedal may no longer be able to travel (pressed down) far enough to reach the factory set position for maximum water flow. Recalibrating the system will allow you to set a new maximum/full water flow position for the foot pedal, when it is pressed.

System Calibration Process

****The calibration sequence will time out after 2 minutes of no input. If the system times out, simply start the calibration process over.****

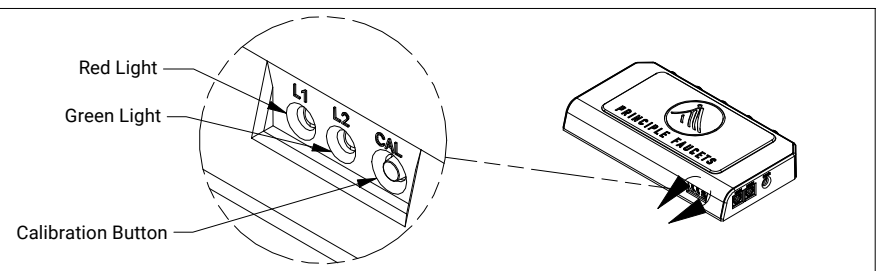
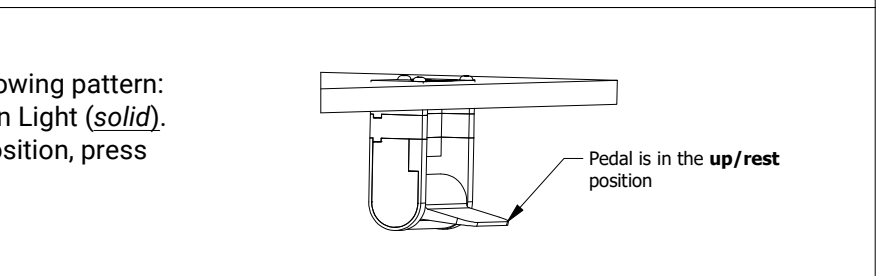
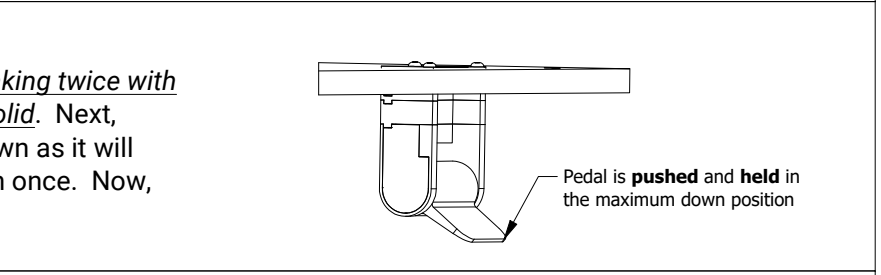
<ol style="list-style-type: none">1. Locate the Calibration Button (CAL) at the back of the Engine Box (21).2. Press and hold the CAL button (+2sec), until both red and green lights blink together, then release.	
<ol style="list-style-type: none">3. Wait until the lights have changed to the following pattern: Red Light (<i>blink once with a pause</i>) and Green Light (<i>solid</i>). While the Foot Pedal (27) is in the up/rest position, press and release the CAL button once.	
<ol style="list-style-type: none">4. Check that the Red Light has changed to <i>blinking twice with a pause</i> and the Green Light has remained <i>solid</i>. Next, press and hold the Foot Pedal (27) as far down as it will travel; then press and release the CAL button once. Now, release the Foot Pedal (27).	
<ol style="list-style-type: none">5. The system will confirm a successful calibration when the lights change to the following pattern: Red Light <i>solid</i> and Green Light <i>blinking slowly</i>. <p>NOTE: If the calibration is unsuccessful, you may get an Error State Light Sequence. Explanations and solutions for the Error State Light Sequences can be found in the Trouble Shooting Guide under Error State Light Sequences.</p>	